

Operation manual

Cncreza.ir

OMICRON AC Servo Drives MK6-series



750w up to 1.5kw,

Digital pulse command input,

1 or 3 phase 220VAC input supply voltage,

Matched for OMEGA AC Servo Motors (with 15-line









2500 ppr incremental encoder),

CONTENTS

1	provisions for safe and proper use of equipment -----	2
1.1	electric shock injury warning	2
1.2	warning of damage to equipment	2
1.3	fire warning	3
	environmental requirements	3
2	product inspection and model description -----	3
2.1	product inspection	3
	product model definition	4
3	installation -----	6
3.1	notes	6
3.2	environmental conditions	7
3.3	installation of servo drive	7
3.4	installation of servo motor	8
	determination of motor rotation direction	11
4	interface and connection -----	111
4.1	notes	111
4.2	description of terminals	111
4.3	CN1 I/O control signals connector	12
4.4	CN2 motor encoder (feedback) connector	14
4.5	I/O connection types	15
	connection requirements for main input power supply	199
5	Display and keypad operation -----	20
5.1	keypad operation	20
5.2	layer 1	20
5.3	layer 2	21
6	Parameters -----	26
6.1	summary of parameters	26
	parameter functions	27
7	Protection Functions -----	32
7.1	alarm list.....	32
	alarm troubleshooting	32
8	Operation-----	36
8.1	working sequence	36
8.2	notes	37
8.3	important notes before operation	38
8.4	"self-test" mode of operation	38
8.5	running drive in "position" control mode	39
8.6	running drive in "pulse speed" control mode	40
8.7	adjustment	41
8.8	FAQs	41
	APPENDIX (I): motor code (PA1) table -----	42
	APPENDIX (II): drive specifications-----	43







1. Provisions for safe and proper use of equipment

1.1 Electric shock injury warning





 Warning	
	When the servo drive is powered on, do not open the cover of the drive. There is the risk of electric shock.
	When the cover of the drive is open, do not power on the drive. There is the risk of touching any exposed high-voltage part.
	For repair of the servo drive, wait for at least five minutes after cutting off the input power then check both leads of the high-voltage capacitor by using a voltmeter. The repair operation is allowed only when you are quite sure that the capacitor voltage is below the safe voltage level.
	Power on only after reliable installation of the servo drive.
	Servo drive and servo motor must be properly grounded.
	Do not touch the servo drive with wet hands or you may be in the risk of electric shock.
	Wrong voltage level or mistake in power supply connection may cause an explosion or operational accidents.
	Ensure that the wires are properly insulated to avoid short circuit and electric shock.

1.2 warning of damage to equipment

 Warning	
---	--

-  Do not connect input power supply to the U, V, W of output terminals of the servo drive or the servo drive is damaged.
 -  The servo motor and servo drive should be connected together directly through cables & connectors which have been prepared for this purpose by the factory. Do not connect the U, V, W output terminals of the servo drive to any capacitive element (e.g. noise suppression filter, pulse interference limiter, etc.) or breaking contactors, or the drive will be damaged.
 -  Connect the input power of the servo drive to a suitable electricity network as determined in the technical specification table of the drive.
 -  Please double check the correctness of the cable connections before energizing the servo drive.
 -  Please use the motor with suitable drive. Improper selection of any part may damage the drive or motor.
- The rated torque of the servo motor should be higher than the effective continuous load torque by 30% at least, for suitable working condition of the motor and drive and avoid short life time of them.
-  The ratio between the load inertia and servo motor inertia should be less than the recommended value. Otherwise the motion of the load will be oscillatory and unstable and the drive will not work properly.

1.3 fire warning

 Warning	
Parameters	Conditions
Humidity	≤90% (non-condensation)
Operating temperature	0 +40°C (no condensation)
Storage temperature	-40 +55°C
Elevation	Less than 1,000 meters from sea level
Vibration	Less than 0.5G (4.9m/s ²), 10-60Hz (non-continuous operation)
Environment atmosphere	No corrosive and flammable gas or oil mist
 Warning	
<ul style="list-style-type: none">  The servo drive should not be installed on the surface of a combustible material and should be kept away from flammable materials. Otherwise, the materials may get fired.  Do not use the servo drive at places with high moisture, full of corrosive gas or flammable gas which they could damage the electronic board and components.  When any abnormal situation occurs while the drive is in operation, cut off the input power immediately for troubleshooting. Long-time overloaded operation of the drive may cause damage and fire. 	

1.4 environmental requirements

2 product inspection and model description ~ ~

2.1 product inspection

After purchase and transportation and before use, please make detailed inspection over the following items:

- a. Check whether it is your ordered product. Check the product model of the motor and drive respectively.
- b. Check whether the motor shaft runs smoothly. Rotate the motor shaft counterclockwise and clockwise by hand. If it runs smoothly, it means that the rotor of the motor is under normal conditions.
- c. Check whether there is any damage in the appearance of the products. Check for any damage in the appearance via visual inspection or if any screw is loosened.
- d. Check whether any component is missing.

The complete servo components include:

- 1 Servo motor and servo drive.

6))))) Servo drive operation manual. 2

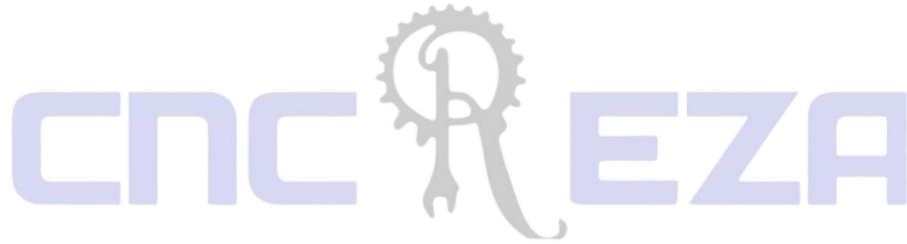

سازنده انواع ماشین آلات صنعتی و ماشین مخصوص

WWW.CNCREZA.IR

5PIN power input terminal jack (r, t, R, S,

T).

- 4 4PIN motor output power terminal jack (U, V, W and PE).
- 5 MDR20, a 20pin connector for encoder connection.

Please contact us for a proper solution in any of the above mentioned items are missed.

2.2 product model definition

2.2.1 Servo drive

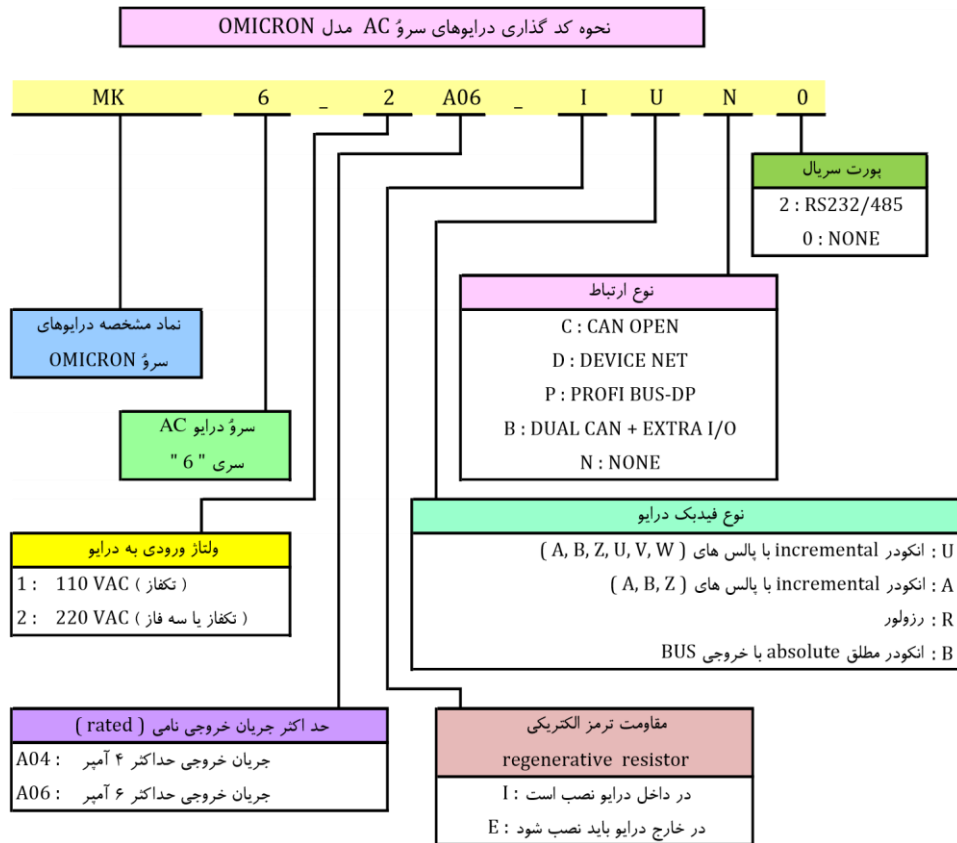

2.2.2 Servo motor

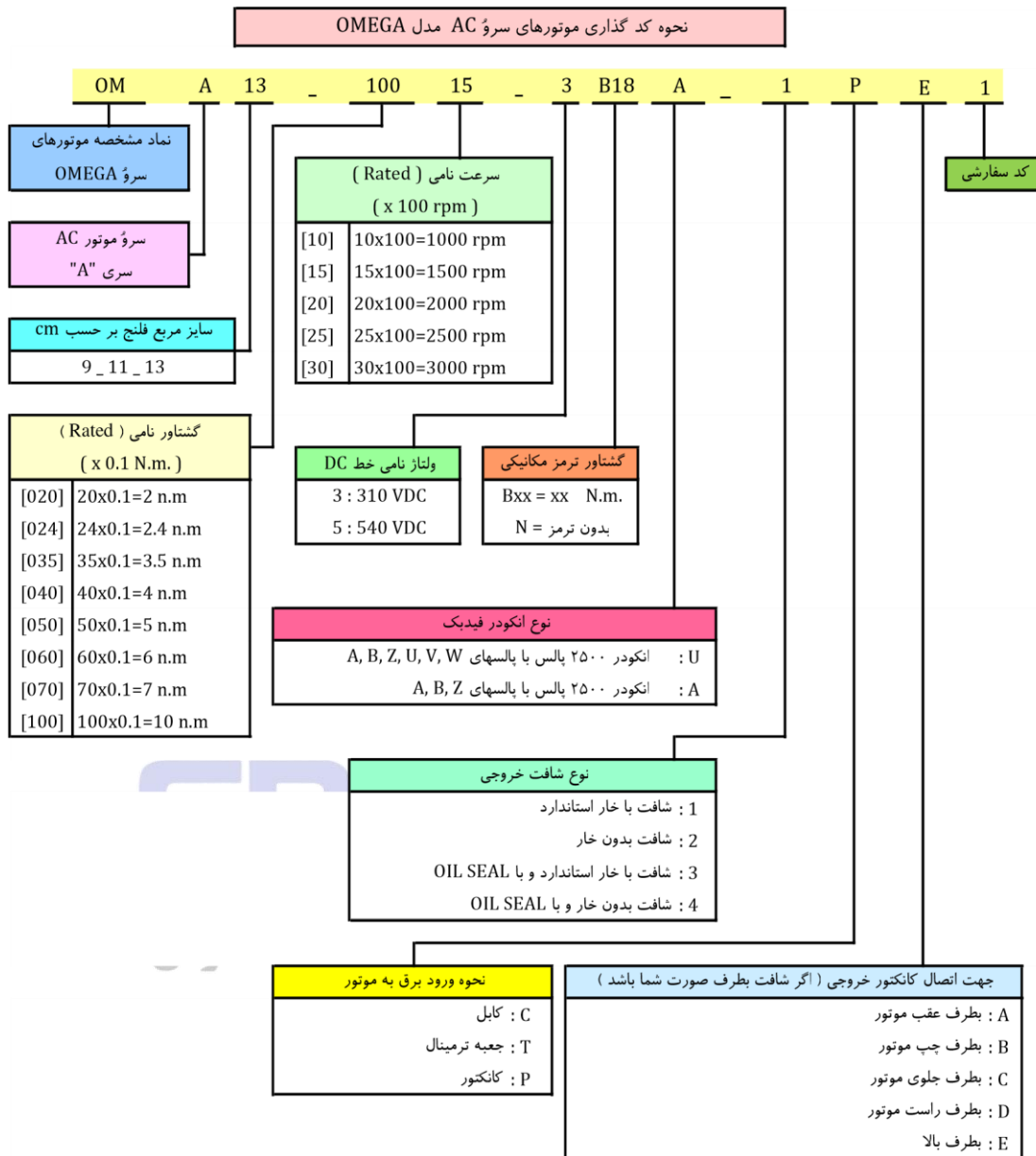

2.2.3 Matching table for motors and drives

جدول مشخصات فنی سرو موتورهای مدل OMEGA و درایوهای مدل OMICRON سری MK6 مناسب آنها

	كود موتور مدل OMEGA	مشخصات فني موتور	كود درايو مدل OMICRON	كلاس حفاظتي
سري 90	OMA9 - 02430 - 3NU - 1CC1	2.4 N.m , 3000 rpm , 0.75 kw , 3 A	MK6 - 2A04 - IUN0	IP54
	OMA9 - 03520 - 3NU - 1CC1	3.5 N.m , 2000 rpm , 0.73 kw , 3 A	MK6 - 2A04 - IUN0	
	OMA9 - 04025 - 3NU - 1CC1	4 N.m , 2500 rpm , 1 kw , 4 A	MK6 - 2A06 - IUN0	
سري 110	OMA11 - 02030 - 3NU - 3PE1	2 N.m , 3000 rpm , 0.6 kw , 2.5 A	MK6 - 2A04 - IUN0	IP65
	OMA11 - 04030 - 3NU - 3PE1	4 N.m , 3000 rpm , 1.2 kw , 5 A	MK6 - 2A06 - IUN0	
	OMA11 - 05030 - 3NU - 3PE1	5 N.m , 3000 rpm , 1.5 kw , 6 A	MK6 - 2A06 - IUN0	
	OMA11 - 06020 - 3NU - 3PE1	6 N.m , 2000 rpm , 1.2 kw , 4.5 A	MK6 - 2A06 - IUN0	
سري 130	OMA13 - 04010 - 3NU - 3PE1	4 N.m , 1000 rpm , 0.4 kw , 2.9 A	MK6 - 2A04 - IUN0	
	OMA13 - 04025 - 3NU - 3PE1	4 N.m , 2500 rpm , 1 kw , 4 A	MK6 - 2A06 - IUN0	
	OMA13 - 05025 - 3NU - 3PE1	5 N.m , 2500 rpm , 1.3 kw , 5 A	MK6 - 2A06 - IUN0	
	OMA13 - 06010 - 3NU - 3PE1	6 N.m , 1000 rpm , 0.6 kw , 3.5 A	MK6 - 2A04 - IUN0	
	OMA13 - 06025 - 3NU - 3PE1	6 N.m , 2500 rpm , 1.5 kw , 6 A	MK6 - 2A06 - IUN0	
	OMA13 - 07020 - 3NU - 3PE1	7 N.m , 2000 rpm , 1.4 kw , 6 A	MK6 - 2A06 - IUN0	
	OMA13 - 10010 - 3NU - 3PE1	10 N.m , 1000 rpm , 1 kw , 4.5 A	MK6 - 2A06 - IUN0	
OMA13 - 10015 - 3NU - 3PE1	10 N.m , 1500 rpm , 1.5 kw , 6 A	MK6 - 2A06 - IUN0		

Table 2-1
Motor & Drive matching table

3 installation

3.1 notes

- The servo drive must be installed reliably and fixing screws must be fastened tightly to avoid vibration.
- The connection between the servo drive and servo motor should not be stretched tightly to avoid any over-tension on the cables. The wiring of the power line and encoder line should not be adjacent together in close distance. It is better to lay them in separate conduits.
- Dust or iron filings should be prevented from entering into the drive during installation.
- The axis of the motor shaft and the axis of the load shaft should be within little deviation. The misalignment of the axes has to be compensated by a flexible coupling of proper torque capacity.
- The motor must be installed firmly.
- The servo drive, servo motor and brake resistor (in case of need) should not be in contact with flammable materials to avoid any risk of fire.
- Impact over the drive or motor is prohibited.
- The storage and operation condition of the drive and motor must meet the required environmental conditions as in 3.2.

3.2 environmental conditions

Item	Requirements on servo drive	Requirements on servo motor
Working environment temperature / humidity	-10°C to 55°C Humidity to be less than 80%	0°C to 40°C Humidity to be less than 80%

Storage environment temperature / humidity	-25°C to 70°C Humidity to be less than 80%	-40°C to 50°C Humidity to be less than 80%
Vibration	Less than 0.5G	
Other working conditions	To be used in control cabinet, free from dust, dry, no corrosive gas and combustible gas, few moisture, well-ventilated, avoiding direct sunlight	Indoor, no corrosive gas or inflammable materials, no direct sunlight

3.3 installation of servo drive

3.3.1 Mounting dimensions

The front view of servo drive is shown in Figure 3-1.

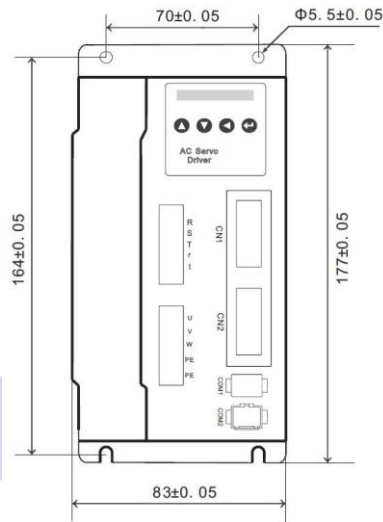

Figure 3-1 Front View The

side view of drive is shown in Figure 3-2.

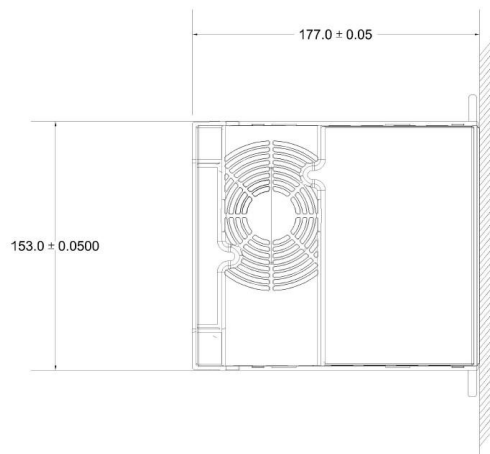

Figure 3-2 Side View

3.3.2 Installation

The four screws at the back of the drive should be tightened.

3.3.3 Installation clearance

Required clearance between the drive and control cabinet box and between other electronic equipments should be left.

Minimum clearance requirements are shown in Figure 3-3.

3.3.4 Ventilation and heat dissipation

If more than one drive is installed in the control cabinet, the cooling requirements for each of them should be taken into account. Cooling fan should be provided in the electrical control cabinet, ensuring that there is enough vertical blowing air to cool the drives. The minimum clearance requirements for this purpose are shown in Figure 3-4.

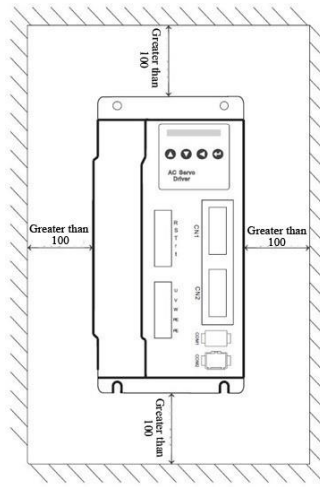

Figure 3-3 Installation clearance requirements for single drive

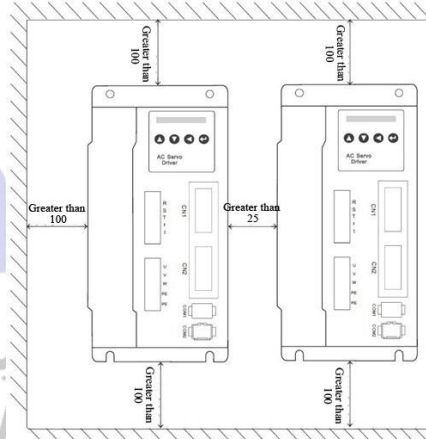

Figure 3-4 Installation clearance and cooling requirements for multiple drives

3.4 installation of servo motor

3.4.1 Installation method

Horizontal installation: To avoid water, oil, coolant or any liquid from flowing into the power connector or encoder connector of motor, the cable outlet should be provided downward at the bottom.

Vertical Installation: If the motor shaft is installed upward and a reducer (gearbox) is assembled on it, measures must be taken to prevent penetrating grease or oil of the reducer into the motor via the motor shaft. The motor shaft must have oil seal in this case.

3.4.2 Installation precautions

- In assembling and disassembling of pulleys, do not knock the motor shaft with a hammer to avoid damage to the motor bearing or the encoder. Use a suitable pulling tool when disassembling the pulley.
- Too loose installation of the motor may cause vibration and disengaging of the load from motor.
- Do not apply excessive axial or radial force on the motor or the bearings are damaged. A flexible coupling is recommended for the transmission of mechanical power.

3.4.3 Mounting dimensions of motor

The mounting dimensions of motor are as shown in Figure 3-5 (a) (b) below.

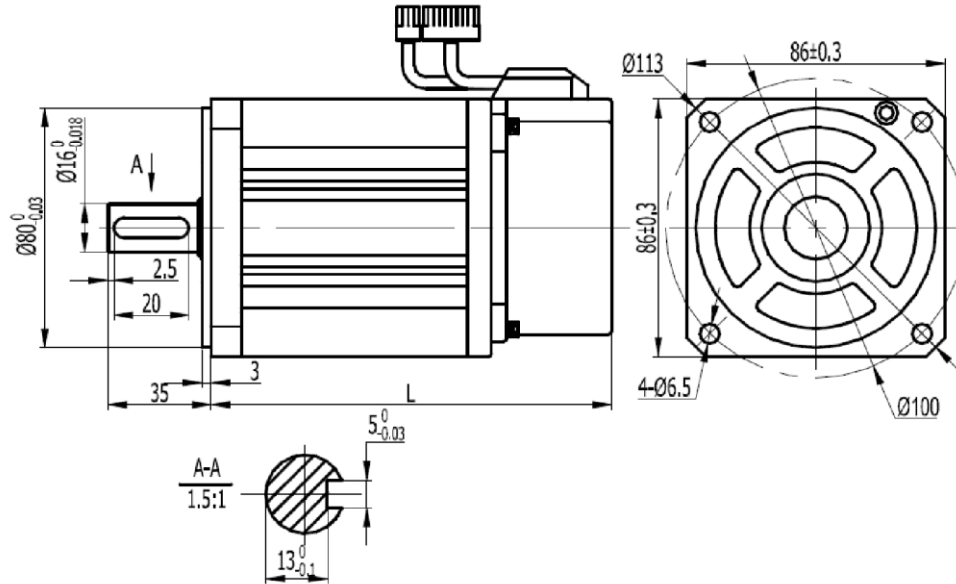

Figure 3-5 (a)

مشخصات ابعادي موتورهاي سرو AC مدل OMEGA سري 90			
4	3.5	2.4	گشتاور نامي (N.m)
1000	730	750	توان نامي (watt)
2500	2000	3000	سرعت (rpm)
181	171	149	طول موتور (LA)

Table 3-1

Dimensions of AC Servo motors (90-series)

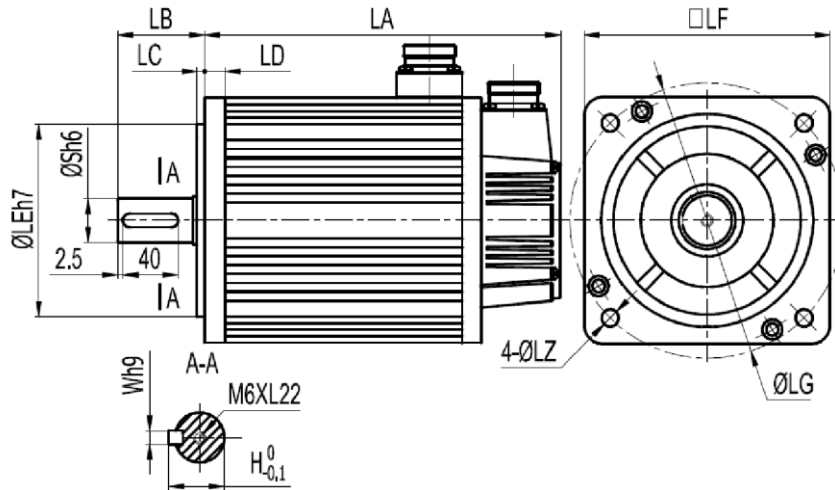

Figure 3-5 (b)

مشخصات ابعادي موتورهاي سرو AC مدل OMEGA سري 110					
6	5	4	2	گشتاور نامي (N.m)	
1.2	1.8	1.5	0.8	1.2	0.6
توان نامي (KW)					
2000	3000	3000	2000	3000	3000
سرعت (rpm)					
219	204	189	159	طول موتور (LA)	
55	55	55	55	طول شافت (LB)	
5	5	5	5	پله نامي (LC)	
12	12	12	12	ضخامت فلنج (LD)	
95	95	95	95	قطر نامي (E)	
110	110	110	110	سايز فلنج (LF)	
130	130	130	130	نقشه را ببينيد (LG)	
9	9	9	9	سوراخ جاي پيچ (LZ)	
19	19	19	19	قطر شافت (S)	
6	6	6	6	پهناي خار (W)	
21.5	21.5	21.5	21.5	نقشه را ببينيد (H)	

Table 3-2 Dimensions of AC Servo motors (110-series)

مشخصات ابعادي موتورهاي سرو AC مدل OMEGA سري 130							
10	7	6	5	4	گشتاور نامي (N.m)		
1.5	1	1.4	1.5	0.6	1.3	1	0.4
توان نامي (KW)							
1500	1000	2000	2500	1000	2500	2500	1000
سرعت نامي (rpm)							
213	192	179	182	171	166	169	طول موتور (LA)
57	57	57	57	57	57	57	طول شافت (LB)
5	5	5	5	5	5	5	پله نامي (LC)
14	14	14	14	14	14	14	ضخامت فلنج (LD)
110	110	110	110	110	110	110	قطر نامي (E)
130	130	130	130	130	130	130	سايز فلنج (LF)
145	145	145	145	145	145	145	نقشه را ببينيد (LG)

9	9	9	9	9	9	9	LZ (سوراخ جاي پيچ)
22	22	22	22	22	22	22	S (قطر شافت)
6	6	6	6	6	6	6	W (پهناي خار)
24.5	24.5	24.5	24.5	24.5	24.5	24.5	H (نقشه را ببينيد)

Table 3-3 Dimensions of AC Servo motors (130-series)

3.5 determination of motor rotation direction

In this manual, the motor rotation direction is defined as follows: when you face the motor flange with the shaft toward you, if the shaft rotates counterclockwise, it is called positive direction; and when the shaft rotates clockwise, it is negative direction. See Figure 3-6.

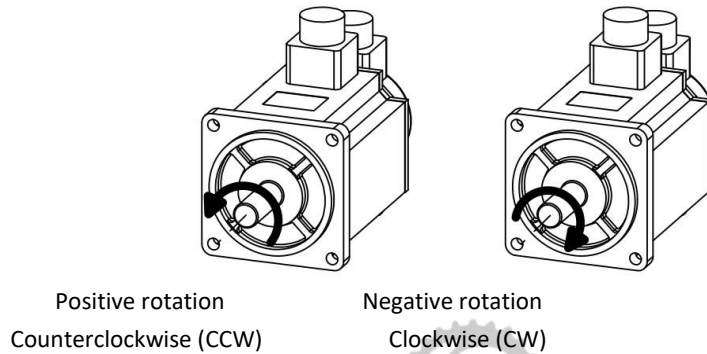

Figure 3-6 Rotation Direction of Motor

4 interface and connection

4.1 notes

- The wiring should be carried out by professional technical staff.
- For wiring or maintenance, firstly, cut off the main power supply, and DO NOT start the work until the power indicator is completely off after about ten minutes.
- Make sure the servo drive and servo motor are properly grounded.
- No damage on the surface of the connecting cables is allowed. Do not hang any heavy object on the connecting cables.

4.2 description of terminals

As shown in Figure 4-1, the power indicator shows whether the power is connected. If the power indicator is still on, it means that electricity has remained in the power capacitors. Please DO NOT open the housing or start any wiring operation in order to avoid electric shock. Buttons and seven-segment display are components for settings and display of parameters. Refer to Table 4.1 for designation of other terminals on the drive panel and their respective functions.

Terminal	Function	Precautions for Use
U,V,W	Motor power line connection terminals	Must be connected to the motor U, V and W correspondingly. They MUST BE in correct order and sequence.
R,S,T r,t	Main input power supply and control power terminals	R, S, T is the main circuit power input terminal AC220V, 50HZ. You can use either 1-phase or 3-phase 220VAC (line to line). DO NOT connect it with the motor output terminals U, V or W. DO NOT connect it to 380VAC. r, t is the control circuit power supply input terminal AC220V, 50HZ.

CN1	communication port for DI/O and input command	Note the definition of each terminal port. Refer to Section 3.3 for the definition
CN2	Motor encoder (feedback) connection port	Note the definition of each terminal port. Refer to Section 3.4 for the definition
PE	Ground terminal (chassis)	Motor and drive must be reliably grounded when in operation.
COM1	Communication port	No use for user.
COM2	Communication port	No use.

Table 4-1 Description of drive terminals

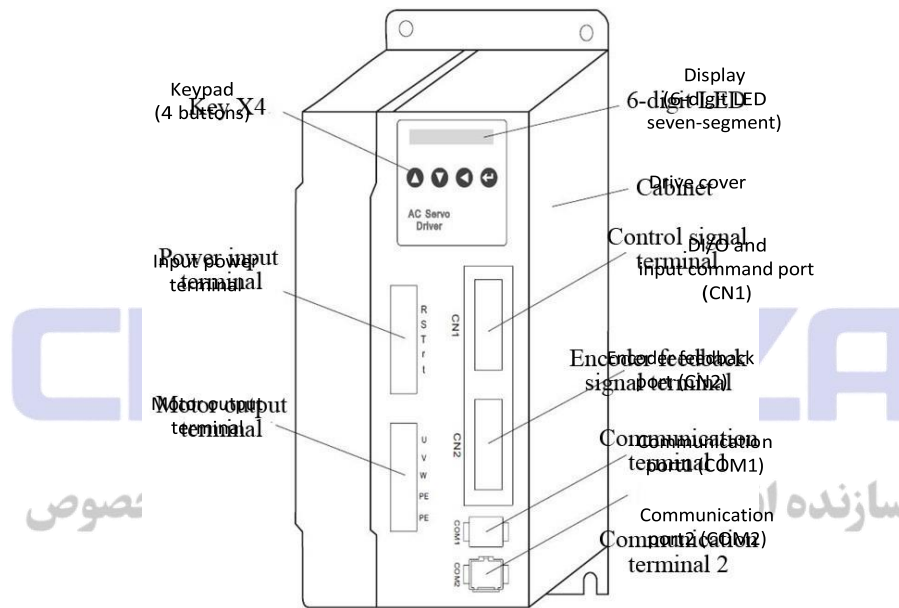

Figure 4-1

Drive terminals and ports introduction

4.3 CN1 Input / Output control signals connector

4.3.1: Configuration of CN1 I/O control connector

Figure 4-2 shows the configuration of the 26-pin I/O control signal port CN1.

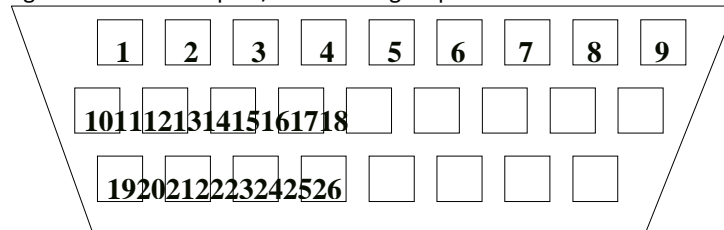

Figure 4-2

CN1 I/O Control signal port (soldering side)

4.3.2: CN1 function descriptions

Abbreviation of control mode:

“P” refers to “position control mode” and “S” refers to “speed control mode”

Table 4.2 CN1 function descriptions of I/O control signals

Pin No.	Signal	Name	I/O connection type	Control mode	Function
14, 23	Positive lead for external power supply input (+24vdc)	COM+	Type1	P, S	Positive end of 24vdc external power supply, used to excite the opto-coupler input terminal. DC12-24V, current ≥ 100mA;
7, 16	Negative lead for external power supply input (GND)	COM-	Type2	P, S	Negative end of 24vdc external power supply (GND)
6	Servo-enable	SON	Type1	P, S	If this pin is short-circuited to COM-, SON is ON, it means that the drive is SERVO-ON, allowing the drive to run. if it is disconnected from COM-, SON is OFF, it means that the drive is SERVO-OFF, and stops working and the motor is off and free to move. Note 1: Before turning SON from OFF to ON, the motor must be stationary. Note 2: When SON is turned ON, wait for 50ms before commencement of any command.
5	Command pulse inhibit	INH	Type1	P	To activate or deactivate the position command pulse input to the drive use INH input. If INH is short-circuited to COM-, then INH is ON and as result, command pulse input is deactivated. If INH is disconnected from COM-, then INH is OFF and command pulse input activated. For normal operation of drive in position mode, this input should be kept unconnected.
15	Alarm clear	ACLR	Type1	P, S	When the drive shows some alarm and you need to clear the alarm, you have to turn ON the ACLR by short circuiting it to COM- . If it is disconnected from COM-, ACLR is OFF. For normal use of drive, this pin should be left unconnected.
12	Command pulse input	PULS+	Type3	P	Command pulse and direction input opto-couplers. See the wiring schematic for more information.
3		PULS-			
13	Command direction input	SIGN+	Type3	P	
4		SIGN-			
22, 24	Shield	FG		P, S	Shielding of the cable is connected to this pin. Be careful that only drive side of the cable shield from controller to drive is connected to shield pin. The shield of the cable at controller side is left unconnected.

25,26	Reserve				
1	Encoder A-phase signal output	A+	Type5	P, S	1. Encoder A, B, Z signal differential output (line driver, 26LS31 output, equivalent to RS422) 2. Non-isolated output (non-insulated)
2		A-			
10	Encoder B-phase signal output	B+	Type5	P, S	
11		B-			
19	Encoder Z-phase signal output	Z+	Type5	P, S	
20		Z-			
9	Encoder Z-phase open collector output (collector)	Z+	Type6	P, S	Encoder Z-phase opto-coupler output. See the schematic for more information.
8	Encoder Z-phase open collector output (emitter)	Z-			
18	Servo alarm output	ALM	Type2	P, S	If any alarm happens in the servo drive, the ALM output is turned on, and as result this pin is pulled up to COM+. If alarm is removed and drive is in normal condition, this output is pulled down to COM-, and ALM is turned off.

4.4 CN2 motor encoder (feedback) connector

4.4.1 Configuration of CN2

Figure 4-3 shows the configuration of CN2, the 15-pin motor encoder connector.

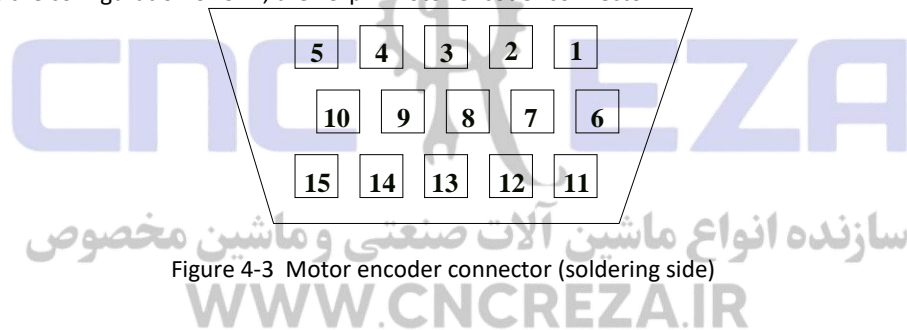

Figure 4-3 Motor encoder connector (soldering side)

4.4.2 CN2 function descriptions

Table 4.3 Function descriptions of motor encoder connector CN2

Pin No.	Signal	Name	I/O connection type	Function
6	Encoder Power supply (+5vdc)	+5V		The servo motor encoder uses +5 Vdc power supply. If the cable length is too long (longer than 5 meters), use multi-core cable for parallel connection of wires in order to make bigger cross-section power route.
1	Encoder Power ground (gnd)	GND		
2	Encoder A +	A+	Type7	Connected to servo motor optical encoder A+ signal
3	Encoder A -	A-		Connected to servo motor optical encoder A- signal
4	Encoder B +	B+	Type7	Connected to servo motor optical encoder B+ signal
5	Encoder B -	B-		Connected to servo motor optical encoder B- signal
10	Encoder Z +	Z	Type7	Connected to servo motor optical encoder Z+ signal

15	Encoder Z -	Z-	Type7	Connected to servo motor optical encoder Z- signal
14	Encoder U +	U+		Connected to servo motor optical encoder U+ signal
9	Encoder U -	U- +		Connected to servo motor optical encoder U- signal
13	Encoder V +	V+	Type7	Connected to servo motor optical encoder V+ signal
8	Encoder V -	V-		Connected to servo motor optical encoder V- signal
12	Encoder W +	W+	Type7	Connected to servo motor optical encoder W+ signal
7	Encoder W -	W-		Connected to servo motor optical encoder W- signal
11	Shield	FG		Shield screen of the cable.

4.5 I/O connection types

1) Type1 digital input connection type

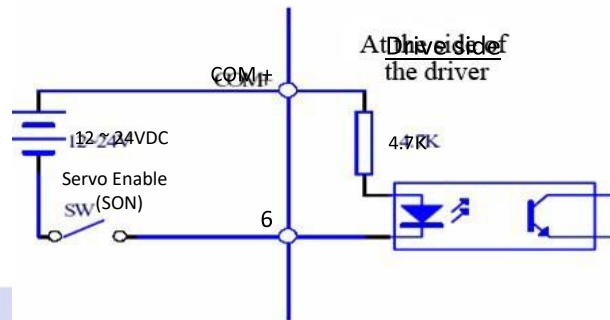

Figure 4-1
Type1 Switch input connection method

☑ Power supply is externally provided by the user, input DC 12-24V from the COM + pin, current capacity $\geq 100\text{mA}$;

☑ **IMPORTANT NOTE:** if the 24VDC power supply polarity is reversed, the servo drive will not work;

2 Type2 Transistor output connection type

)

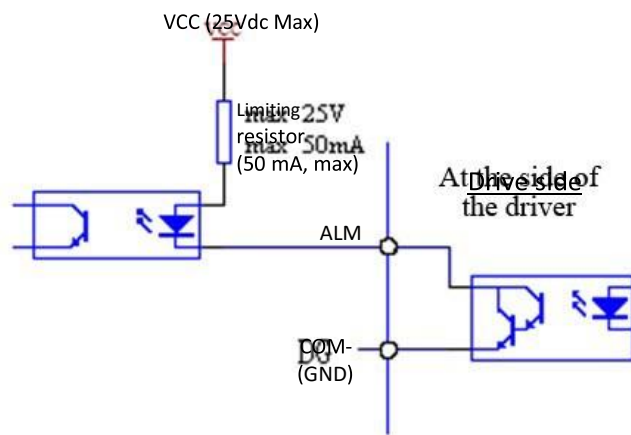

Figure 4-2a

Type2 Opto-transistor output connection method (an opto-coupler as load)

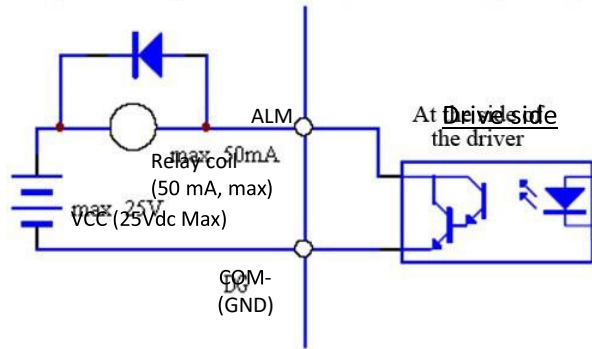

Figure 4-2b

Type2 Opto-transistor output connection method (a relay as load)

- ❑ Use Darlington transistor for the output, connected with the opto-coupler (Figure 4-2a) or relay (Figure 4-2b);
- ❑ External power supply is provided by the user, but note that if the power supply polarity is reversed, the servo drive would be damaged;
- ❑ The output is an open-collector opto-transistor, with the maximum current of 50mA, and external power supply voltage of 25Vdc. Therefore, the load must meet this limit. If it exceeds this limit or the output is directly connected to the power supply, the servo drive would be damaged;
- ❑ If the load is inductive load (e.g. relay in figure 4-2b), anti-parallel freewheeling diode is required. If the polarity of freewheeling diode is reversed, damage to the servo drive and the diode itself may occur;
- ❑ The output transistor is a Darlington transistor. In the conduction, the voltage drop V_{ce} between the collector and the emitter is about 1V, which cannot meet the TTL low level requirements, and should not be directly connected with the TTL IC;

3) Type3 pulse input interface

CNC or Controller side

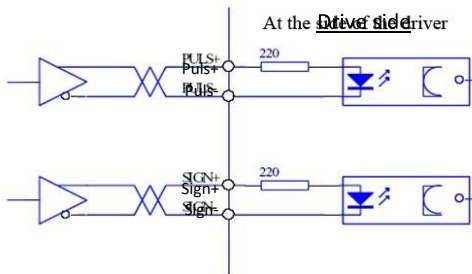

Figure 4-3a Type 3, differential line driver configuration of input pulse command

PLC or Controller side

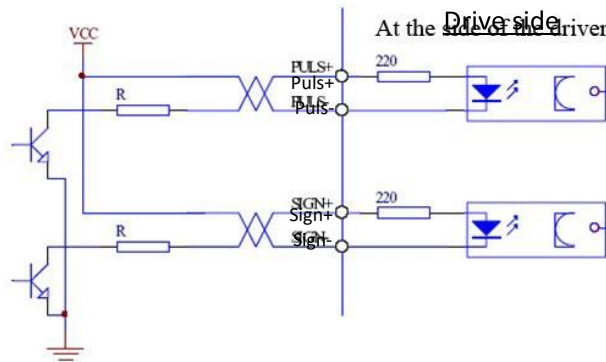

Figure 4-3b Type3, Single-ended configuration of input pulse command

- ☐ In order to transmit pulse number correctly, and improve anti-jamming capability, differential line driver mode is recommended (Figure 4-3a);
- ☐ Differential line driver configuration adopts AM26LS31, MC3487 or similar RS422 line driver;
- ☐ Use single-ended configuration for lower operation frequencies of up to 200KHz. According to the pulse input circuit, the drive consumption current is 10-15mA. The maximum voltage of the external power supply is 25Vdc. in order to determine the resistor R (limiting resistor) you can refer to these practical data:
If VCC = 5V, R = 120-330Ω ; if VCC = 12V, R = 680Ω-1.2K ; if VCC = 24V, R = 1.8-2.7K
- ☐ If the single-ended configuration mode is used, the external power supply is needed to be provided by the user. Note that if the power supply polarity is reversed, the servo drive would be damaged.
- ☐ The input command pulse form is shown in Table 4.4. The arrow indicates the count. Table 4.5 shows the timing and parameters of pulse input.

Table 4.4 Pulse input form

Pulse command form	CCW	CW	Parameter set value
Pulse train			0
Sign			Command pulse + sign
CCW pulse train			1
CW pulse train			CCW pulse / CW pulse

Table 4.5 Input command pulse timing and parameters

Parameter	Differential drive input	Single-end drive input
t_{ck}	$>2 \mu S$	$>5 \mu S$
t_h	$>1 \mu S$	$>2.5 \mu S$
t_l	$>1 \mu S$	$>2.5 \mu S$
t_{rh}	$<0.2 \mu S$	$<0.3 \mu S$
t_{rl}	$<0.2 \mu S$	$<0.3 \mu S$
t_s	$>1 \mu S$	$>2.5 \mu S$
t_{qek}	$>8 \mu S$	$>10 \mu S$
t_{qh}	$>4 \mu S$	$>5 \mu S$
t_{ql}	$>4 \mu S$	$>5 \mu S$
t_{qrh}	$<0.2 \mu S$	$<0.3 \mu S$
t_{qrl}	$<0.2 \mu S$	$<0.3 \mu S$
t_{qs}	$>1 \mu S$	$>2.5 \mu S$

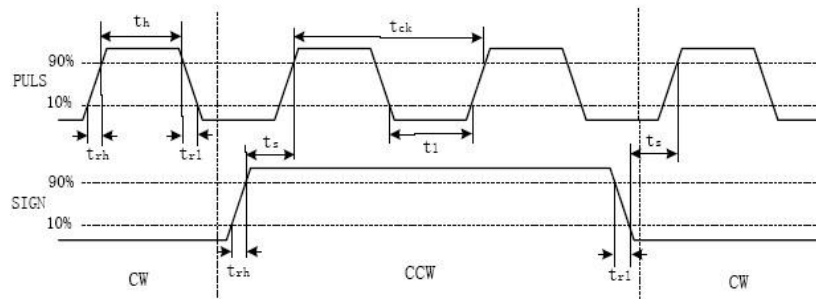

Figure 4-4

PULSE + SIGN input command timing diagram
(maximum pulse frequency is 500kHz, using differential line driver mode)

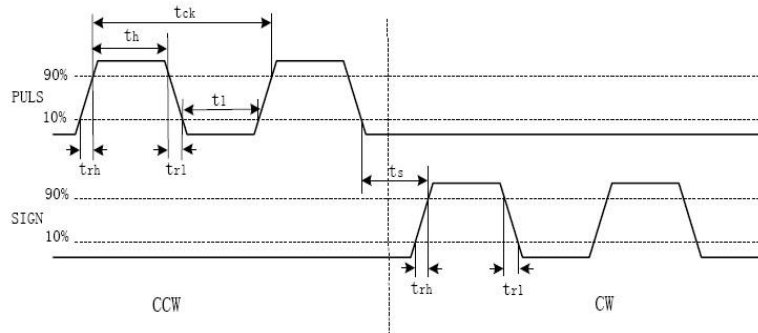

Figure 4-5

CW / CCW pulse input command timing diagram
(maximum pulse frequency is 500kHz, using differential line driver mode)

4 Type5 encoder signal output interface

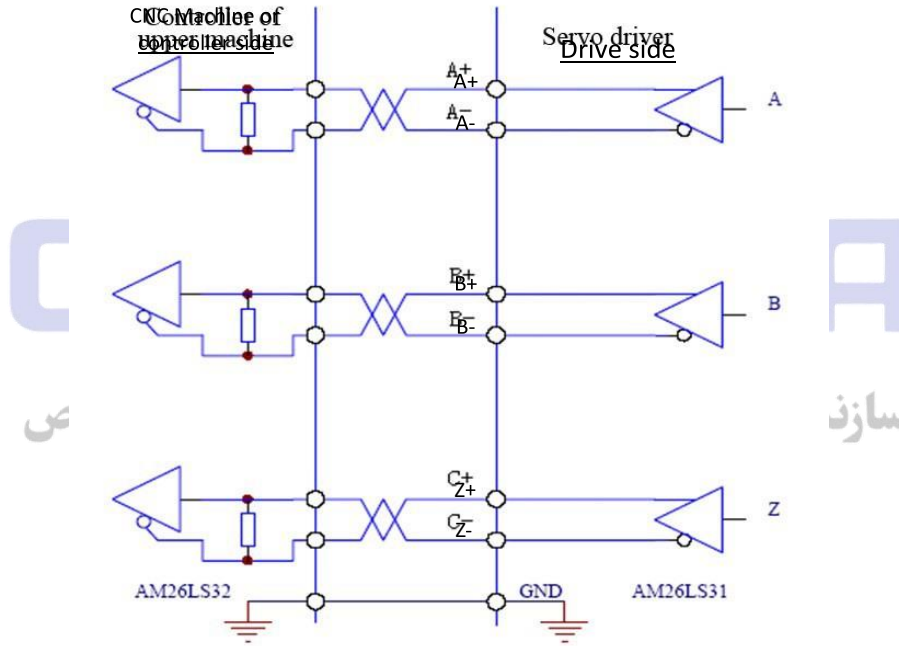

Figure 4-6a Type5 optical encoder output signal

Encoder signals are output via the differential line driver (AM26LS31); The input terminal of CNC controller

may be AM26LS32 receiver and must be connected to a terminating

resistor of approximately 330Ω;

The ground wire of CNC controller and the ground wire of servo drive must be reliably connected;

Non-isolated outputs, as shown in Figure 4-6a;

The input terminal of CNC controller may be an opto-coupler for the receiving purpose, but high-speed opto-coupler must be used (e.g. 6N137) as shown in Figure 4-6b;

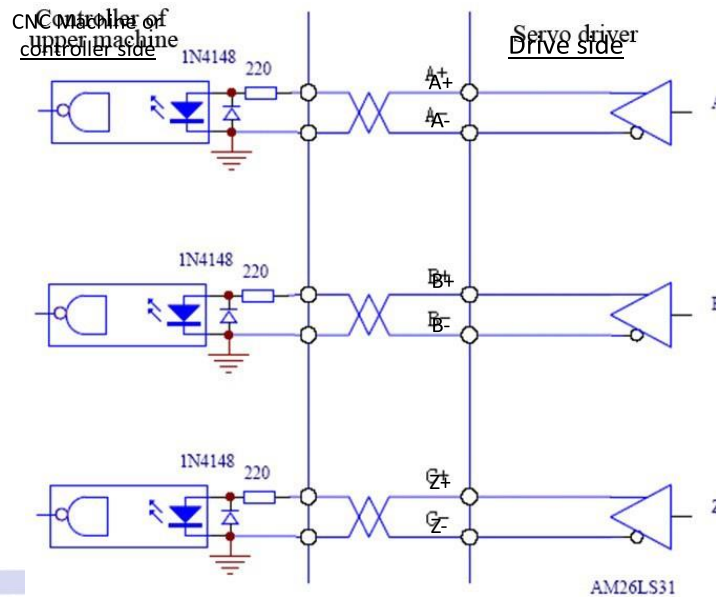

Figure 4-6b Type5 optical encoder output signal

5Type6 encoder Z-phase signal, open-collector output interface

سازنده انواع ماشین آلات صنعتی و ماشین مخصوص
WWW.CNCREZA.IR

VCC (25Vdc Max)

Limiting resistor

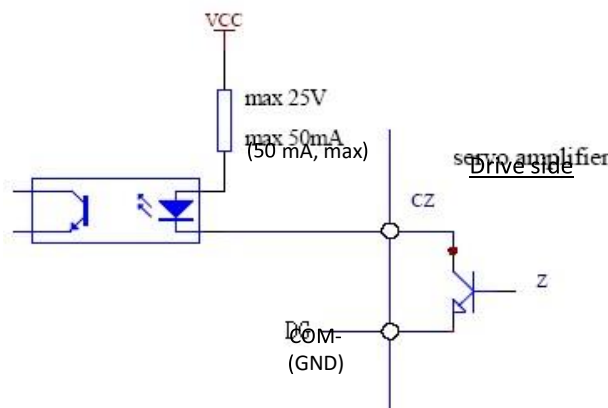

Figure 4-7 Type6 optical

encoder output interface

Encoder Z-phase signal is output via the open-collector transistor. When the encoder Z-phase signal appears, it [□] _□ outputs ON (output turn-on), otherwise it outputs OFF (output turn-off);

Since in the Host controller (CNC controller), Z-phase signal impulse is usually narrow, high-speed opto-coupler (e.g. 6N137) is recommended;

6 Servo motor optical encoder input interface
)

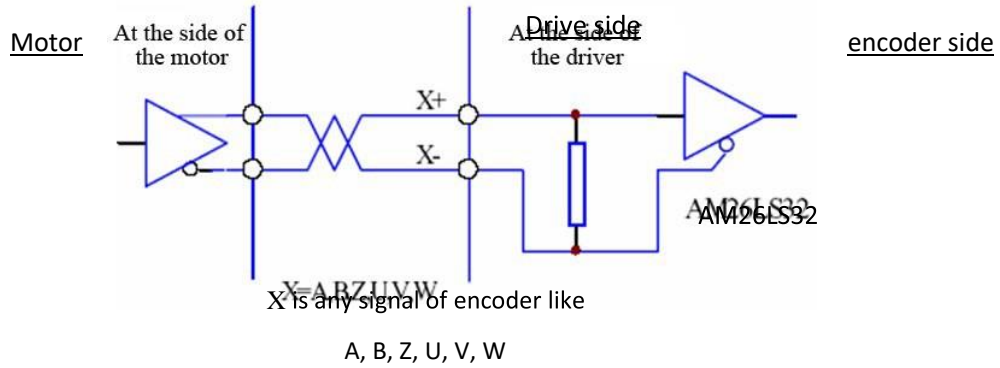

Figure 4-8
Type7 servo motor optical encoder input interface

4.6 connection requirements for main input power supply

- 1 A three-phase isolated transformer is recommended to supply the input power to servo drive, as this reduces the possibility of electric shock or any unwanted voltage rise. Although it is not a MUST, and you can still use single phase network, as long as the voltage level and current capacity of the supplying line is in range.
- 2 Noise filter is recommended to improve anti-jamming capability; 3' . Please provide a non-fuse breaker (NFB) to cut off the external power supply promptly in case of drive

failure;

- 4 The grounding wire should be $\geq 2.5\text{mm}^2$, as thick as possible, and is of a single-point grounding type. The ground terminal of the servo motor and the ground terminal PE of servo drive must be connected to ground separately;
- 5 To prevent malfunction due to interference, noise filter is recommended and note that: noise filter, servo drive and the host controller should be installed as close together as possible;

- 6 Proper connection of the shield layer of cables must be done; relay, AC contactor, brake and other coils should be provided with surge suppressor; the power circuit cables and signal line or encoder line should not be bundled together or laid in one conduit. They have to be laid in separate metal conduits in the shortest route; .

5 Display and keypad operation

5.1 Keypad operations

The drive panel consists of six LED 7-segment digital displays and four keys (“↑”, “↓”, “←” and “Enter”) for setting parameters and to display drive status.

Key functions are as following:

- “↑”: To increase the number or value, or to change the function folder.
- “↓”: To reduce the number or value, or to change the function folder.
- “←”: To return to the operation menu at the previous layer, or to cancel the operation.
- “Enter”: To enter the operation menu at the next layer or to input for confirmation.

The operations are designed in layers. “←” and the “Enter” key mean to move backwards and forwards in the layer, respectively. The “Enter” key means to enter and to confirm, while the “←” key means to exit and cancel. “↑” and “↓” mean to increase and decrease the number or value, respectively. If “↑” and “↓” are pressed down together, it has the double effect. The longer it is maintained is the higher the repetition rate.

5.2 LAYER 1

There are multi layers of operating menus. The first layer is the main menu, including three operation modes, and the second layer is the function menu of various operation modes. Figure 5-1 shows the operating diagram of the main menu:

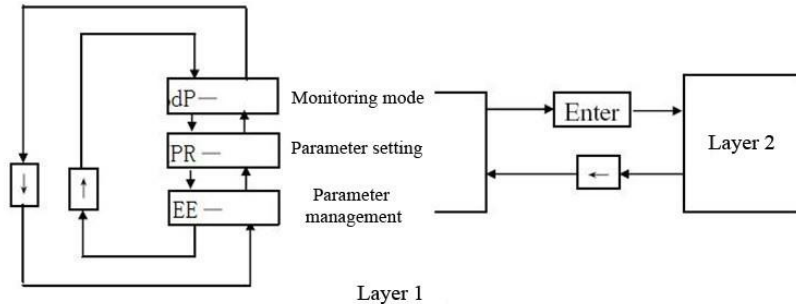

Figure 5-1
Operating diagram of mode selection

5.3 LAYER 2

5.3.1 Monitoring mode

Select “dP-“ in layer 1 and press “Enter” to enter the monitoring mode. There are 21 display statuses. The user needs to push “↑” or “↓” to select the desired display mode. Then press “Enter” and it enters a specific display.

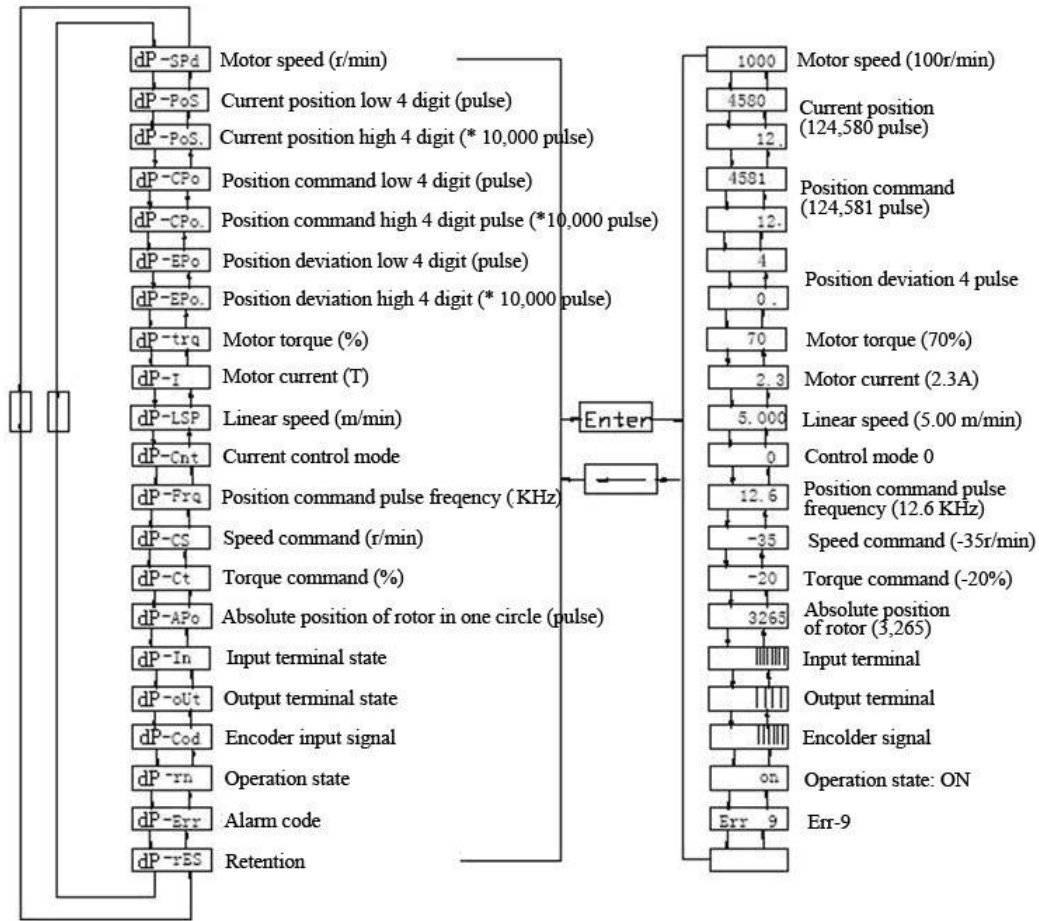

Figure 5-2
Operating diagram of monitoring mode

[Note 1] Both the position pulse and the command pulse are the multiplied values through the electronic gear value.

[Note 2] Pulse unit is the pulse unit of the system and in this system; it is 10,000 pulses / rev. The pulse number is represented using high 4 digits + low 4 digits and is calculated as follows:

$$\text{Pulse number} = \text{high 4-digit value} \times 10,000 + \text{low 4-digit value}$$

[Note 3] Control mode: 0 - position control; 1 - Pulse speed control;

[Note 4] Under the pulse speed mode, the position command pulse frequency is the pulse speed. The unit is rpm.

It is a positive number in the positive direction and a negative number in the negative direction. [Note

5] The motor current “I” is determined as follows

$$I = \sqrt{\frac{2}{3}(I_U^2 + I_V^2 + I_W^2)}$$

[Note 6] In one rotation, the absolute position of the rotor refers to the position relative to the location of stator. One rotation is a cycle and the range is 0 to 9,999.

[Note 7] The input port status display, the output port status display, and the encoder signal display are shown in Figure 5-3 to figure 5-5, respectively.

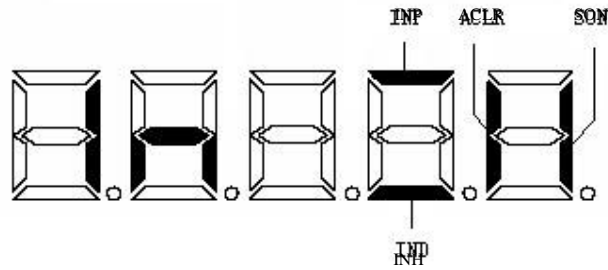

Figure 5-3:

Input port status display (Segments are “ON” when their relevant inputs are “ON” and are “OFF” when they are “OFF”)

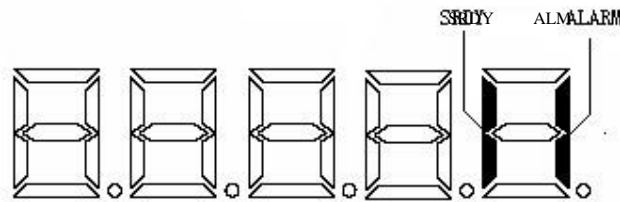

Figure 5-4

Output port status display (Segments are “ON” when their relevant outputs are “ON” and are “OFF” when they are “OFF”)

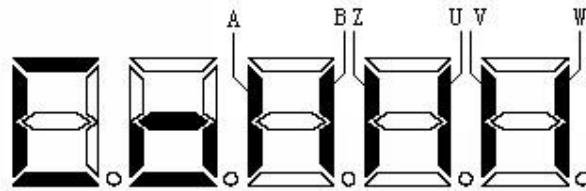

Figure 5-4 Encoder signal display

(The bottom parts of the segments are constantly “ON”. When the upper part is “ON” it indicates “ON” and when it is “OFF”, it indicates “OFF”)

(Z signal: It turns “ON” or “OFF” for each “Z” pulse) [Note 8]

The operation status is expressed as follows:

“Cn- oFF”: The main circuit is not charged and the servo system is not running;

“Cn- oFF”: The main circuit is charged and the servo system is not running;

(The servo is not enabled or the alarm exists);

“Cn- on”: The main circuit is charged and the servo system is running;

[Note 9] The panel displays alarm "Err -", indicating drive status and with some alarm.

5.3.2 Parameter settings

Select "PA-" in the first layer, and press “Enter” to enter the parameter setting mode. Use “↑” or “↓” to select the parameter number and press “Enter” to display the parameter value. Use “↑” or “↓” to change the parameter value. Press “↑” or “↓” key once and the parameter value increases or decreases by 1. Press and hold “↑” or “↓”, the parameter increases or decreases continually. When the parameter value is modified but not applied yet, the decimal point at the rightmost seven-segment digit is “ON”. Press “Enter” to confirm the value and the decimal point is “OFF”. The

modified value will be immediately activated in the drive performance. Press “↑” or “↓” to continue to modify the parameter. When the parameter modification is finished, press “←” to return back to the parameter selection mode. If you are not satisfied with the value being modified, do not press “Enter” for confirmation, but you should press “←” to cancel it and the parameter will restore the original value and it returns to parameter selection mode.

Please be noted that some important parameters require for parameter writing operations and you need to re-power-on the drive before it becomes effective.

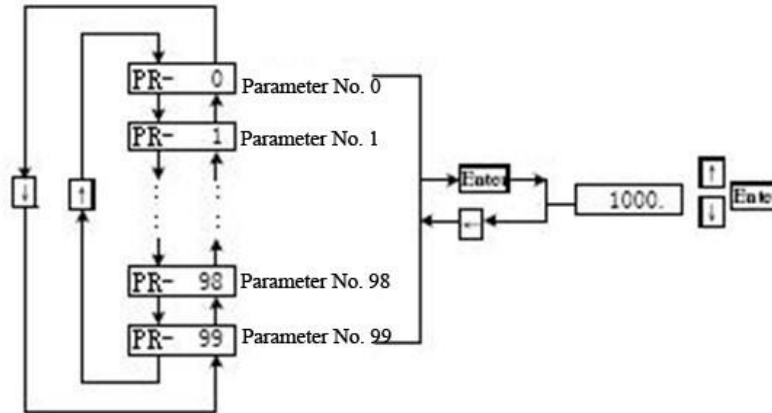

Figure 5-5
Operating diagram of parameter setting



5.3.3 Parameter management

Parameter management is mainly responsible for operations between the memory processing unit and EEPROM. Select "EE-" in layer 1 and press "Enter" to enter parameter setting mode. Firstly, select the operating mode. There are five modes available and you need to use "↑" and "↓" to select. Choose "Parameter writing" for example, select "EE-Set" and then press "Enter" and keep it for more than 3 seconds. If the writing operation is successful, the display shows "done". If it fails, it displays "Error". Then press "←" to return to the operating mode selection folder.

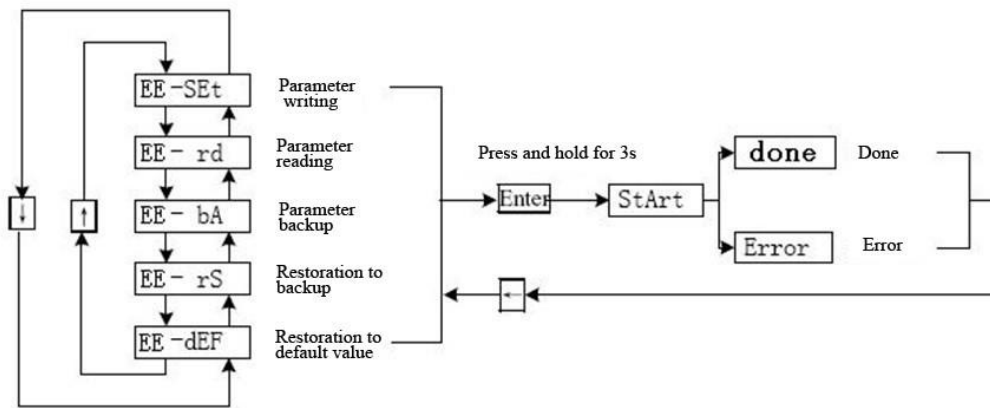

Figure 5-6:
Operating diagram of parameter management

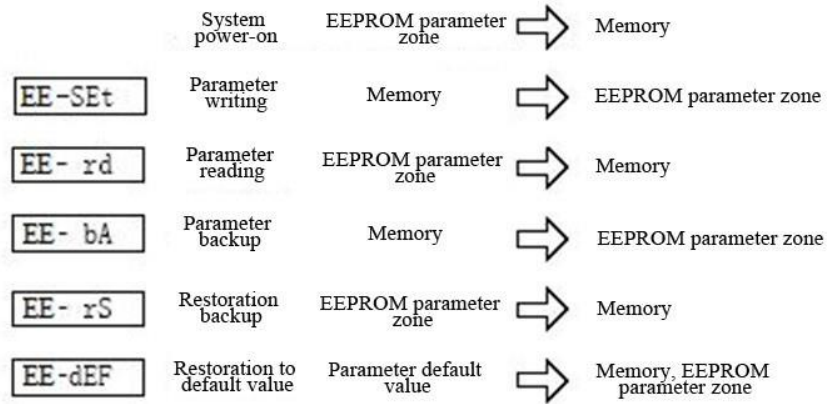

Figure 5-7
Operating meanings diagram of parameter management

- ② “EE-Set” parameter writing: to write parameters from memory to the EEPROM parameter zone. When the parameter is modified by the user, it is only a change to the parameter value left in the memory and it will be restored to the original value next time you power it ON. To permanently change the parameter value, you need to perform parameter writing operations. Write the parameter from memory to the EEPROM parameter zone and it will not be restored to the original value next time when you power it ON.
 - ② “EE-rd” parameter reading: to read data from EEPROM parameter zone and transfer it to the memory. It is run automatically at the time the drive is powered ON. At first, the memory parameter value is the same as that in the EEPROM parameter zone. The memory parameter will be changed when the parameter is changed by the user. If the user is not satisfied with the modified parameter or the parameter become disordered, parameter reading operation will once again read the data from the EEPROM parameter zone and transfer it to the memory and thus restore it to its value when it is powered ON.
 - ② “EE-bA” parameter backup: to write memory parameter to the EEPROM backup zone. The EEPROM is divided into parameter zone and backup zone for storage of two sets of parameters. At system power-ON, parameter writing and parameter reading operations use the EEPROM parameter zone, while parameter backup and restoration backup use the EEPROM backup zone. In parameter setting, if the user is relatively satisfied with a set of parameters but would like to continue to modify any parameter, the user may firstly start parameter backup operation to save the memory parameters into the EEPROM backup zone, and then modify the parameters. If the effect of modification becomes worse, the user may read parameters saved in the EEPROM backup zone last time in order to transfer to the memory, and then the user may once again start to change the parameters.
- In addition, when the parameters are set, the user may perform parameter writing or parameter backup operations, so that the data in the EEPROM parameter zone is the same as those in the backup zone. In case of accidental unwanted parameter changes, you may restore the backup by reading the data from EEPROM backup zone to transfer it into the memory. Then you may start parameter writing operation to write the memory parameter into the EEPROM parameter zone.
- ② “EE-rS” restoration backup: to read the data from the EEPROM backup zone to the memory. Note that no parameter writing operation is performed and the data from the EEPROM parameter zone will be transferred to the memory when next time it is powered ON. If the user needs to use the parameter in the EEPROM backup zone, parameter writing operation is required.
 - ② “EE-dEF” restoration default value: to read the default value of all parameters from the memory and write them into the EEPROM parameter zone. The default parameters will be activated when next time it is powered ON. If the parameters are disordered, so that the drive fails to work properly, use this operation to restore all parameters back

to the default value. Since different motor models correspond to different parameter default values, in using the restoration default parameters in any drive, you must ensure the correctness of the motor model by checking parameter PA1.



6 Parameters

6.1 Summary of Parameters

Parameter no.	Items	Password changing	Parameter range	Default value	Unit
0	Password		0~1000	385	
1	Motor model	385	0~10	5	
2	Software version	385		30	
3	Initial display status	385	0~19	0	
4	Control mode selection	385	0~1	1	
5	Software enabled	385	0~1	0	
6	Position loop proportional gain	385	1~999	35	1/s
7	Electronic gear ratio Numerator	385	1~9999	1	
8	Electronic gear ratio Denominator	385	1~9999	1	
9	Pulse input mode selection	385	0 4	0	
10	Command pulse direction reversed	385	0~1	0	
11	Positioning completion range	385	0~9999	8	Pulse
12	Lag error detection range	385	0~9999 ~	300	×100 Pulse
13	Lag error activation mode	385	0~2	0	
14	System hidden parameters	385	0~1024	0	
15	Encoder pulse feedback frequency division factor	385	1~4096	1	
16	Encoder feedback direction setting	385	0~1	0	
17	Pulse speed mode: speed command low-pass filter constant	385	0~1024	110	
18	Pulse speed mode: speed coefficient numerator (denominator = 1024)	385	0~4096	1024	
19	Pulse speed mode acceleration	385	5~1000	55	$m s/2$
20	Pulse speed mode deceleration	385	5~1000	55	$m s/2$
21	Speed loop proportional gain	385	5~300	35	Hz
22	Speed loop integration time constant	385	5 3000	300	Ms
23	Speed command low-pass filter constant	385	0~1200	9	
24	Speed controller input limiter	385	1~300	63	
25	Speed feedback low-pass filter constant	385	20~200	100	

26	Maximum speed limit	385	0~4000	1050	r/min
27	Motor test speed setting	385		100	r/min
28	Reserve				
29	Reserve				
30	Reserve				
31	Current loop proportional gain	385	1~9999	3500	
32	Current loop integration time constant	385	0~9999	200	Ms
33	Current command low-pass filter cutoff frequency	385	1~200	80	Hz
34	Motor rated current	385	0~160	45	0.1A
35	Motor overload current	385	0~160	68	0.1A
36	Maximum current (torque) limit of drive	385	0~160	80	0.1A
37	Reserve				
38	Reserve				
39	Reserve				
40	Reserve				
41	Reserve				

6.2 Parameter Functions

سازنده انواع ماشین آلات صنعتی و ماشین مخصوص

Parameter no.	Items	Functions	Scope
0	Password	<ul style="list-style-type: none"> ① Used to prevent parameters from being mistakenly modified. Generally, if you need to set the parameters, firstly this parameter is set to the desired password. After completion of debugging, this parameter needs to be set to 0 to ensure that parameters will no longer be mistakenly modified. ② There are different levels of passwords corresponding to the user parameter and the internal parameters. ③ To modify the motor model parameter (PA 1), password is required. ④ User password is 315. ⑤ Motor model modifying password is 385. ⑥ Operation mode selection password is 385. 	
1	Motor model	<ul style="list-style-type: none"> ① Corresponding to the servo drive and motor of different power levels. ② Different motor models correspond to different parameter default values. In using restoration default parameters, you must ensure the correctness of this parameter. 	See Appendix (I) for motor codes table

2	Software version	To view software version number, but no change is allowed. (Read-only).	
3	Initial display state	<p>Selecting the display state after power-ON the drive.</p> <p>0: motor rotational speed; 1: current position low 4 digits; 2: current position high 4 digits; 3: position command (command pulse accumulation) low 4 digits; 4: position command (command pulse accumulation) high 4 digits; 5: position error low 4 digits; 6: position error high 4 digits; 7: motor torque; 8: motor current; 9: motor linear speed; 10: control mode; 11: position command pulse frequency; 12: speed command; 13: torque command; 14: absolute position of the rotor in one turn; 15: input port status; 16: state of output port; 17: encoder input signal; 18: operating status; 19: alarm code; 20: reserve.</p>	
4	Control mode selection	<p>To set the operation mode of the drive:</p> <p>0: position control mode; 1: pulse speed mode; 5: motor self-test mode.</p>	
5	Internal Servo-ON	Set to 1 to substitute the hardware SON signal of the input port.	
6	Position loop proportional gain	<p>① To set the proportional gain of position loop regulator.</p> <p>② Greater value leads to higher gain and rigidity. So, under the same frequency command pulse conditions, the position lag is diminished, if gain is increased. However, if the value is too large, it may cause oscillation or overshoot.</p> <p>③ Parameter value may be determined according to the specific servo drive, motor model and load.</p>	
7	Electronic gear ratio Numerator	<p>① To set the frequency division or multiplication factor of the position command pulse (electronic gear ratio).</p> <p>② In the position control mode, PA 7 and PA 8 parameter settings easily match a variety of pulse sources in order to achieve the desired control resolution (i.e., the angle / pulse).</p> <p>③ $P \times G = N \times C \times 4$ P: number of pulses of the input command; G: Electronic gear ratio; $G = PA\ 7 / PA\ 8$ N: number of motor turns; C: number of encoder lines / rev. Encoder resolution for OMEGA servo motors is 2,500 pulse/rev.</p> <p>④ [Example] When the input command pulse is 6,000, the servo motor rotates one complete turn if: $G = N \times C \times 4 / P = 1 \times 2500 \times 4 = 5/3$ Parameter No. 7 is set 5 and No. 8 is set 3.</p> <p>⑤ The recommended range of electronic gear rate: $1 / 50 \leq G \leq 50$</p>	

8	Electronic gear ratio Denominator	Refer to parameter P7	
9	Pulse input mode selection	0: Pulse + direction 1: CW pulse + CCW pulse(CW/CCW) 2: A and B orthogonal pulse	
10	Command pulse direction reversed	0: normal; 1: Position command pulse direction reversed.	
11	Positioning completion range		
12	Lag error detection range	① To set the lag error detection range. ② In the position control mode, when the count value of the position error counter exceeds the value of this parameter, the servo drive sends the position lag error alarm.	×100 pulse
13	Lag error activation mode	0: lag error alarm detection is effective. 1: lag error alarm detection is not effective. 2: To stop the detection of all alarm errors.	
14			
15	Encoder pulse feedback frequency division factor	No frequency division exists when the value is 0 or 1; 2 means encoder output signal frequency is divided by 2, and so on.	
16	Encoder feedback direction setting	0: Positive feedback. 1: Feedback direction reversed.	
17	Pulse speed mode: speed command low-pass filter constant	1 to 1024. Greater set value leads to higher cutoff frequency. When it is set to 1024, no low pass filter exists.	
18	Pulse speed mode: speed coefficient numerator	In the pulse speed mode, the electronic gear ratio (PA 7 / PA 8) is not valid. This factor can be used to adjust the speed according to the following example. The denominator is 1024. Example: When the motor speed in pulse speed mode is A (rpm), the actual speed will be: Actual speed = A × (PA18 ÷ 1024) (rpm).	
19	Pulse speed mode: acceleration	Unit: rps (cycles per second); the larger the number, the faster the response (Note that the behavior is opposite relative to acceleration time in usual drives, in which, the larger the number leads to slower response).	
20	Pulse speed mode: deceleration	Unit: rps. The larger the number, the faster the response (Note that the behavior is opposite relative to acceleration time in usual drives, in which, the larger the number leads to slower response).	

21	Speed loop proportional gain	<ul style="list-style-type: none"> ① To set the proportional gain of speed loop regulator. ② Greater value leads to higher gain and rigidity. The parameter value is determined according to the model of the servo motor and load. Generally, the greater the load inertia, the greater the set value. ③ The value should be as large as possible if only no oscillation occurs to the system. 	
22	Speed loop integral time constant	<ul style="list-style-type: none"> ① To set the speed loop integral time constant regulator. ② Smaller value leads to faster integral and greater rigidity. The parameter value is determined according to the model of the servo motor and drive and load. Generally, the greater the load inertia, the smaller the set value. ③ The value should be as small as possible if only no oscillation occurs to the system. 	
23	Speed command low-pass filter constant	To set the low-pass filter cutoff frequency of the position loop input feed amount. This filter is used to increase the stability of the total combination of position control.	
24	Speed controller input limiter	The smaller the value leads to less speed fluctuation range and more stable speed.	
25	Speed feedback low-pass filter constant	<ul style="list-style-type: none"> ① To set the speed feedback low-pass filter characteristics. ② The smaller the value, the lower the cutoff frequency and the smaller the noise generated by the motor. If the load inertia is very large, the set value may be appropriately reduced. If the value is too small, the response frequency would be lowered down and oscillation may occur. ③ The greater the value, the higher the cutoff frequency, and the faster the response frequency. If high frequency response is required, the set value may be appropriately increased. 	
26	Maximum speed limit	<ul style="list-style-type: none"> ① To set the maximum speed limit of the servo motor. ② Not related to the direction of rotation. ③ If the set value is greater than the rated speed of motor, the actual maximum speed limit is the rated speed of motor. 	
27	Reserve		
28	Reserve		
29	Reserve		
30	Reserve		
31	Current loop proportional gain	<ul style="list-style-type: none"> ① To set the proportional gain of current loop regulator. ② The higher the set value, the higher the gain and the smaller the current tracking error. However, the gain should not be too high, as this may produce noise or lead to oscillation. ③ Only related to the servo drive and not related to the load. ④ The value should be as large as possible if no oscillation occurs to the system. 	

32	Current loop integral time constant	<p>① To set the integral time constant of the current loop regulator.</p> <p>② The greater the set value, the faster the integral and the smaller the current tracking error. However, the integration time should not be too large as this may produce noise or lead to oscillation.</p> <p>③ Only related to the servo drive and not related to the load. Generally, the greater the electromagnetic time constant of the motor, the smaller the integration time constant.</p> <p>④ The value should be as large as possible if only no oscillation occurs to the system.</p>	
33	Current command low-pass filter cutoff frequency	<p>① To set the current command low-pass filter cutoff frequency. ② Used to limit the current input band, to avoid current shock and vibration, and to ensure stable current response.</p>	
34	Motor rated current	<p>① The rated current of the motor (unit: 0.1A)</p> <p>② Also the current detection level for motor thermal overload protection.</p> <p>③ When the motor current is below this value, the electronic thermal counter does not work (i.e. does not detect the motor thermal overload); when the motor current is higher than this value, it commences counting. When the electronic thermal counter exceeds the threshold value, motor thermal overload alarm occurs. The greater the motor overload thermal alarm, the shorter the alarm formation time. The threshold value is reached when 130% rated current continues to run for 15 minutes. The motor thermal overload alarm indicates that the motor is overheating.</p> <p>④ Generally, PA34 < PA35 < PA36. Otherwise, no overheating load or overload detection conditions would be met.</p> <p>⑤ The default value cannot be changed.</p>	
35	Overload current	<p>① To set the current detection level for motor overload protection.</p> <p>② The set value is the current value (unit: 0.1A).</p> <p>③ When the motor current is below the detection level, the electronic thermal counter does not work (i.e. does not detect the motor overload); when the motor current is higher than this value, it commences counting. When the electronic counter exceeds the threshold value, motor thermal overload alarm occurs. The greater the motor overload amount, the shorter the alarm formation time. The threshold value is reached when drive runs at overload condition for 4 seconds.</p> <p>④ Generally, PA34 < PA35 < PA36. Otherwise, no overheating or overload detection conditions would be met.</p> <p>⑤ The default value cannot be changed. (read-only)</p>	

36	Maximum current (torque) limit	<p>① To set the servo motor torque limit.</p> <p>② The set value is the current value (unit: 0.1A).</p> <p>③ This limit is always valid.</p> <p>④ If the set value is more than overload allowed for the drive, the actual torque limit is the maximum overload allowed for drive.</p> <p>⑤ Generally, PA34 <PA35 <PA36. Otherwise, no overheating or overload detection conditions would be met.</p> <p>⑥ The default value cannot be changed. (read-only)</p>	
37	Reserve		
39	Reserve		
40	Reserve		
41	Reserve		
42	Reserve		

7 Protection Functions 7.1 Alarm List

Alarm code	Alarms	Alarm contents
--	Drive works well	
1	Main circuit over voltage	Main circuit input voltage is higher than maximum tolerated voltage for drive.
2	Main circuit under voltage	Main circuit input voltage is lower than minimum tolerated voltage for drive.
3	IPM module failure	IPM module (intelligent power module) failed.
4	Brake failure	The brake circuit in the drive failed.
5	Overload	Servo drive and motor are overload (instantaneous overheating).
6	Over-speed	The speed of servo motor exceeds the rated value.
7	Position-error	The value of Position deviation counter exceeds the maximum tolerated set value.
8	Position deviation counter overflow	The absolute value of the position deviation counter exceeds 2 ³⁰ .
9	Current sensing circuit failure	Phase Current sensing circuit failed.
10	Encoder failure	Encoder signal error. Signals are lost or out of sequence.
11	Encoder Z pulse lost	Encoder Z pulse lost.
12	EEPROM error	EEPROM error.
13	FPGA error	FPGA error.
14	Motor overheating load	The motor has been in continuous overload condition for more than 15 minutes at a current exceeding the rated value.

7.2 Alarm troubleshooting

Alarm code	Alarms	Operating condition	Causes of fault	Countermeasures
1	Main circuit over voltage	Occurred when input supply voltage is connected to control board of drive	The wiring of brake resistor disconnected	Re-connect it

	Occurred when input supply voltage is connected to main power board of drive	① Brake transistor damaged ② Internal brake resistor broken	Replace the servo drive
	Occurred when motor in operation	Brake resistor wiring disconnected	Re-connect it
		① Brake transistor damaged ② Internal brake resistor broken	Replace the servo drive
		Brake circuit capacity not enough	① Reduce the frequency of start / stops ② Increase deceleration time ③ Reduce the torque limit value ④ Reduce the load inertia ⑤ Replace for a higher power set of drive and motor
	input supply voltage higher than maximum rated value	Check the network supply voltage	

2	Main circuit under voltage	Occurred when input supply voltage is connected to main power board of drive	① power board failure ② Power fuse damaged ③ Soft-start circuit failure ④ power rectifier damaged	Replace the servo drive
			① input supply voltage lower than minimum rated value ② Temporary input power failure for more than 20mS	Check the network supply voltage
	Occurred when motor in operation	① Power capacity of drive not enough ② Instantaneous power failure	Check the input power supply	
3	IPM module failure	Occurred when motor in operation	Radiator overheating	Check the load condition
			① input supply voltage lower than minimum rated level ② Overheating	① Check the drive ② Re-power on ③ Replace the drive
			Short-circuit between drive output terminals U, V and W	Check the connection
			Poor grounding	Properly ground it
			Motor insulation damaged	Replace the motor
			environmental interference	① Increase the line filter ② Keep away from the interference source
	IPM Module failure	Replace the drive		

4	Braking failure	Occurred when input supply voltage connected to control board	Circuit board failure	Replace the control board of servo drive
		Occurred when motor in operation	Brake resistor wiring disconnected	Re-connect it
			① Brake transistor damaged ② Internal brake resistor broken	Replace the servo drive
			Brake circuit capacity not enough	① Reduce the frequency of start / stops ② Increase acceleration / deceleration time ③ Reduce the torque limit value ④ Reduce the load inertia ⑤ Replace for a higher power drive and motor
			input supply voltage higher than maximum rated value	Check the input supply voltage
			Improper parameter setting	Set the parameter properly
			Long-term operation exceeding rated torque	① Check the load ② Reduce the frequency of start / stops ③ Reduce the torque limit value ④ Replace for a higher power drive and motor
			Poor mechanical transmission leading to excess load	Check mechanical parts
5	Overload	Occurred when input supply voltage connected to control board	Circuit board failure	Replace the servo drive
		Occurred when motor in operation	Operating condition exceeding rated torque	① Check the load ② Reduce the frequency of start / stops ③ Reduce the torque limit value ④ Replace for a higher power drive and motor
			Regenerative brake disabled	Check the regenerative brake
			Motor operation unstable and oscillation occurred	① Adjust gains ② Increase acceleration / deceleration time ③ Reduce the load inertia
			① U, V or W outputs to motor is disconnected ② Encoder wiring error	Check the connection

6	Over-speed	Occurred when input supply voltage is connected to control board of drive	<ul style="list-style-type: none"> ① Check for control board failure ② Encoder failure 	<ul style="list-style-type: none"> ① Replace the servo drive ② Replace the encoder of servo motor 	
		Occurred when motor in operation	Input command pulse frequency is too high		Set the input command pulse properly
			Acceleration / deceleration time is too small		Increase acceleration / deceleration time
			Electronic gear ratio too large		Set the value properly
			Encoder failure		Replace the encoder
			Poor connection in encoder cable		Check or replace the encoder cable
			Servo system unstable which leads to overshoot		<ul style="list-style-type: none"> ① Reset the gains to default values ② If the gains cannot be set to the appropriate value, then reduce the load moment of inertia
		Occurred upon "Servo-ON" of drive	Load inertia too large		<ul style="list-style-type: none"> ① Reduce the load inertia ② Replace for a higher power drive and motor
			Encoder signal error		<ul style="list-style-type: none"> ① Replace the encoder of servo motor ② Re-adjust the encoder reference point as defined by manufacturer
			<ul style="list-style-type: none"> ① Wrong connection of motor U, V or W phases ② Wrong connection of encoder cable leads 		Check and connect it properly

7	Position-error	Occurred when input supply voltage is connected to control board of drive	Control board failure	Replace the servo drive
		Motor fails to follow input command pulse	<ul style="list-style-type: none"> ① Wrong connection of motor U, V or W phases ② Wrong connection of encoder cable leads 	Check and connect it properly
			Encoder failure	Replace the encoder of servo motor
		Occurred when motor in operation	Position-error detection range set too narrow	Extend Position-error detection range
			Proportional gain of position loop is too small	Increase gain

			Torque insufficient	<ul style="list-style-type: none"> ① Check the torque limit value and increase it ② Reduce the load on motor ③ Replace for a higher power drive and motor
			Command pulse frequency is very high	Reduce the command frequency
8	Position deviation counter overflow		<ul style="list-style-type: none"> ① Motor is mechanically blocked ② Command pulse abnormal 	<ul style="list-style-type: none"> ① Check the mechanical load parts ② Check the command pulse ③ Check whether the motor rotates correctly as per command pulse frequency and number
9	Current sensing circuit fails		Chip or circuit board damaged	Replace the servo drive
10	Encoder failure		Encoder wiring error	Check the connection
			Encoder damaged	Replace the encoder of the motor
			Poor connection in encoder cable	Check or replace the cable
			Encoder cable too long, resulting in low supply voltage at the encoder end	<ul style="list-style-type: none"> ① Shorten the cable ② Use multi-core cable for parallel connection of wires or higher cross-section leads
			<ul style="list-style-type: none"> ① Poor internal connection in drive circuitry ② Switching power supply error ③ Chip damaged 	<ul style="list-style-type: none"> ① Check the connector ② Check the internal switching power supply of drive for 5VDC to encoder ③ Replace the drive
11	Encoder Z pulse lost		<ul style="list-style-type: none"> ① Z pulse does not exist, the encoder damaged ② Cable damaged ③ Poor encoder cable shielding ④ Shielding ground line is not properly connected ⑤ Encoder interface circuit inside the drive has problem 	<ul style="list-style-type: none"> ① Replace the encoder ② Check the encoder interface circuit
12	EEPROM error		Control circuit board failure	Return for repair
13	FPGA error		Control circuit board failure	Return for repair
14	Motor overheating load	Occurred when input supply voltage is connected to control board of drive	Control circuit board failure	Replace the servo drive
		Occurred when motor in operation	Continuous operation at torque level exceeding the rated value	<ul style="list-style-type: none"> ① Check the load ② Reduce the frequency of start / stops ③ Reduce the torque limit value ④ Replace for a higher power drive and motor

8.1 Working sequence

8.1.1 "Power-ON" sequence

Please refer to Figure 8-1 for power-ON circuit and the following descriptions for its operation sequence:

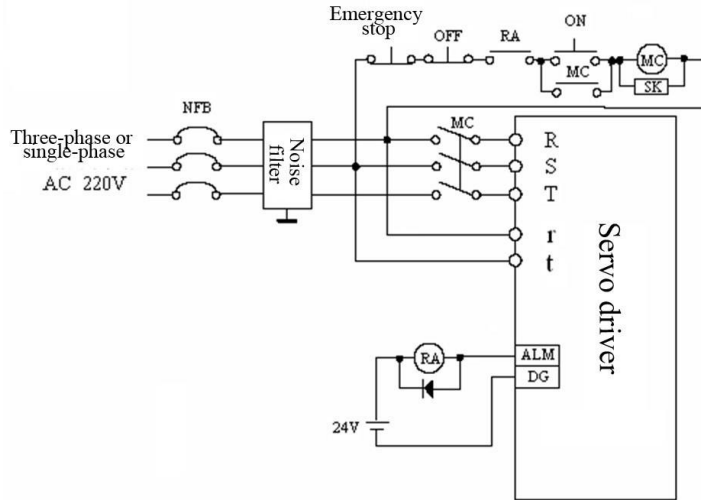

Figure 8-1 "Power-ON" wiring diagram

- 1) Connect input power to the main circuit power input terminals (three phases to R, S and T, or single phase to R and S) via the AC contactor.
- 2) Connect input power to "r" and "t" of the control circuit, parallel to the power section input terminals, or before the main circuit contactor contacts, as in fig. 8-1. If only the control circuit input supply is connected, the servo ready signal (SRDY) is OFF.
- 3) After the main circuit power is turned on, servo ready signal (SRDY) is ON after a 1.5 sec. delay, then the drive is ready to receive servo enable signal (SON) to make the drive ready to run.
- 4) When the servo enabling is connected concurrently with the input power, the supply voltage to the circuit is connected within 1.5 seconds.
- 5) Frequent connection and disconnection of the drive to the input power may damage the soft-start and the dynamic braking circuit. On/off frequency should be no more than five times per hour and less than 30 times a day. If the drive or motor is overheated, wait for 30 minutes after troubleshooting before reconnecting it to the power.

8.1.2 Timing diagram

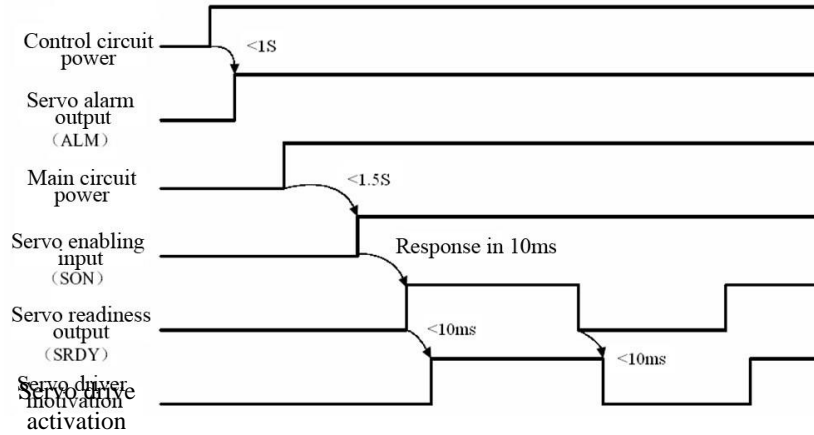

Figure 8-2 Power connection timing sequence diagram

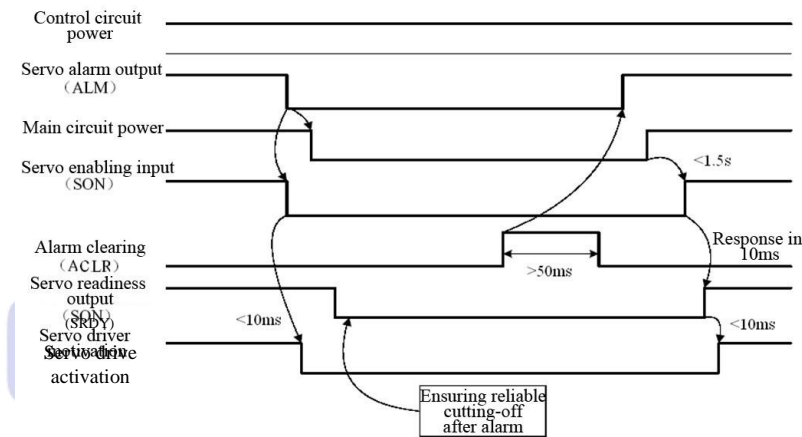

Figure 8-3 Alarm timing sequence diagram

8.2 Notes

1 Start / stop cycles should be determined according to the servo drive and motor and must concurrently meet the two conditions.

(A) Frequency allowed for the servo drive

If high cycle of start / stop per minute is required, check whether it is within the allowed frequency range. The allowed frequency range varies according to the motor type, capacity, load inertia and motor speed. Firstly set the deceleration time to prevent too large renewable energy (in the position control mode, set the output pulse acceleration and deceleration time for the host controller). When the load inertia is m times of the motor inertia, the frequency allowed for the servo motor is as follows:

Multiple of load inertia	Allowed start/stop cycles
$m \leq 3$	> 100 cycles / minute; acceleration and deceleration time: 60 ms or less
$m \leq 5$	60 to 100 cycles / minute; acceleration and deceleration time: 150 ms or less
$m > 5$	< 60 cycles / minute; acceleration and deceleration time: 150 ms or less

If it

still fails to meet the



requirements, reduce the internal current limit (parameter PA34 and PA35) and lower down the maximum motor speed (parameter PA26).

(B) The allowed frequency for the servo motor varies with the load conditions, running time and other factors.

Please refer to the motor manual.

- 2 Generally, if the multiple of load inertia is less than five times, use the motor under large inertia conditions. Main circuit over voltage or braking anomalies may occur from time to time and the countermeasures are as follows:

Reduce internal torque limit (parameter PA34 and PA35);

  Reduce the maximum motor speed (parameter PA26);

-



Providing an additional regeneration device;

- 3 As the servo drive is provided with a power supply for the encoder, to ensure normal operation of the encoder, the output voltage should be maintained at $5V \pm 5\%$. If long cables are used, voltage loss may occur. In this case, please use the multi-core encoder cable for supply voltage in order to reduce the voltage drop throughout the cable line.

8.3 Important notes before operation

After completing installation and wiring, check the following items before power connection:

Whether the power line and the motor line is properly circuited and grounded?

  Whether the encoder cable is connected correctly?

Whether the control signal terminal is properly connected? Whether the 24vdc power supply polarity is suitably connected?

Whether the drive and the motor are firmly fixed?

Whether the motor shaft is NOT connected to the load?

8.4 "self-test" mode operation

1. Press "←" to exit the menu to "PA", enter "PA-4", and then press "ENTER" to set the parameter to "5". This parameter is used to set control mode of the driver:
 - 0: position control mode; 1: pulse speed mode; 5: motor self-test mode (this mode may be used only in the factory test and do not use this method when the motor is under load).
2. Press "←" to return to the previous menu. Press the "↑" or "↓" key to "OL-" and press "ENTER" and then again keep pressing "ENTER" for about 3 seconds, and the motor runs automatically at 100rpm which is default value. If the motor speed needs to be adjusted, just set the motor testing parameter "PA-27". If this parameter is a "positive" value, the motor runs forward; if this parameter is a "negative" value, it runs in reverse direction. Before checking the parameter "PA-27", check the rated speed of the motor. Make sure this parameter should not exceed the rated speed of the motor.
3. Short press "←" and the motor stops running but it is still energized. Long press "←" and the motor stops rotating and is in a free state (not-energized).
4. To save the parameters set, follow the following steps:
 - Select "EE-" in the first layer and press "Enter" to enter the parameter management mode. Firstly select the operating mode. There are five modes available. Use "↑" and "↓" to select. Select "EE-Set" and then press "Enter" and hold for more than 3 seconds, it displays "donE", indicating that the parameters are successfully saved. If it fails, it displays "Error".
5. If the parameters need not be saved, just disconnect the power.
6. Before replacing the motor, cables or drive, be sure to power off the drive.

8.5 Running drive in "position" control mode

8.5.1 Wiring

1. Main input supply voltage terminals, three-phase AC220V, connected to R, S and T terminals; single-phase AC220V, connected to R and S terminals;
2. Control board input supply voltage terminals r and t should be connected to single-phase AC220V;
3. Encoder signal connector CN2 should be properly connected to the servo motor;
4. Input command signal should be applied to the drive as per schematic design in fig "4.3.a" or "4.3.b".

8.5.2 Operation

- (1) Turn-on the power to control and main boards and the display will turn ON;
- (2) Set parameter values according to the following table and write the parameters into EEPROM

Parameter No.	Meanings	Parameter value	Default value
PA4	Control mode selection	0	1
PA7	Electronic gear numerator	To be set by the user	1
PA8	Electronic gear denominator	To be set by the user	1

PA10	Motor rotation direction	To be set by the user	0
------	--------------------------	-----------------------	---

Table 8.1

(3) If no alarm is detected, enable the Servo-ON (SON) digital input. Send low-frequency pulse signal (about 10 kHz) to the drive from the controller, so that the motor runs at some low speed (about 60 rpm);

8.5.3 Setting of Electronic gear ratio

The encoder for this driver is 2,500 pulses / revolution. Any pulse equivalent is available by setting the electronic gear parameters PA7 and PA8.

Note: Any ratio is available by setting any value for the numerator and denominator, but preferably within the range from 1 / 50 to 50.

Number of pulses	Number of motor rotations;	Electronic gear numerator PA7	Electronic gear denominator PA8
10000	1	1	1
5000	1	2	1
3000	1	10	3
800	1	25	2
20000	1	1	2
1000	2 / 3	20	3
4000	3	30	4

Table 8.2 Some examples for showing the relationship between input command pulse number, electronic gear ratio and number of rotations of motor

Input pulse frequency (kHz)	Motor speed (r/min)	Electronic gear numerator PA7	Electronic gear denominator PA8
	$\frac{Frequency \times 60 \times PA12}{10000 \times PA13}$		
300	1800	1	1
500	3000	1	1
100	1200	2	1
100	1800	3	1
50	1000	10	3
200	800	2	3
100	300	1	2

Table 8.3 Some examples for showing the relationship between input command frequency, electronic gear ratio and speed of rotation of motor

8.6 running drive in “pulse speed” control mode

8.6.1 Wiring

1. Main input supply voltage terminals, three-phase AC220V, connected to R, S and T terminals; single-phase AC220V, connected to R and S terminals;
2. Control board input supply voltage terminals r and t should be connected to single-phase AC220V;
3. Encoder signal connector CN2 should be properly connected to the servo motor;
4. Input command signal should be applied to the drive as per schematic design in fig "4.3.a" or "4.3.b".
5. If only speed control is required, the encoder output signal may not be connected. If the external controller is a position controller, then the encoder output signal is needed to be connected to the controller as accurate position feedback.

8.6.2 Operation

- (1) Turn on the power to control and main boards and the display will turn ON;
- (2) Set parameter values according to the following table and write the parameters into EEPROM

Parameter No.	Meanings	Parameter value	Default value
PA4	Control mode selection	1	1
PA10	Motor rotation direction	To be set by the user	0
PA15	Feedback divider coefficient	To be set by the user	1
PA16	Feedback direction	To be set by the user	0
PA23	Speed command low-pass filter constant	To be set by the user	100
PA19	Acceleration	To be set by the user	100
PA20	Deceleration	To be set by the user	150

Table 8-4

- (3) If no alarm is detected, enable the Servo-ON (SON);
- (4) Apply an adjustable frequency pulse train to the drive, and gradually increase the frequency starting from 0, ensuring that the motor speed varies correspondingly. If the signal direction is negated (by changing PA10 or using "SIGN" input), then the direction of rotation of motor will be reversed.

8.7 Adjustment

8.7.1 Basic gain adjustment

(1) Speed control

- ☐ The "speed proportional gain (parameter PA21) should be as large as possible if only no oscillation occurs. Generally, the greater the load inertia is, the greater the speed proportional gain should be.
- ☐ Under given conditions, the "speed integral time constant (parameter PA22) should be as small as possible. If the speed integral time constant is too large, the speed will be severely changed when the load changes. Generally, the greater the load inertia is, the greater the speed integral time constant should be.

(2) Position control

- ☐ Set the appropriate "speed proportional gain" and "speed integration time constant" using the above mentioned method.
- ☐ The "position proportional gain" (parameter PA6) should be as large as possible if only it is within the stable range. Larger position proportional gain leads to better tracking characteristics of the position command and smaller hysteresis error. However, oscillation tends to occur when positioning is stopped.

[Note]: When the “position proportional gain” is small, the system is stable, but the position tracking ability would be diminished and the hysteresis error becomes large.

Refer to the table below for “position proportional gain” settings

Rigidity	Position proportional gain (PA6)
Low	58 118
Medium	118 138
High	138 198

Table 8-5

8.8 FAQs
8.8.1 Restore parameters

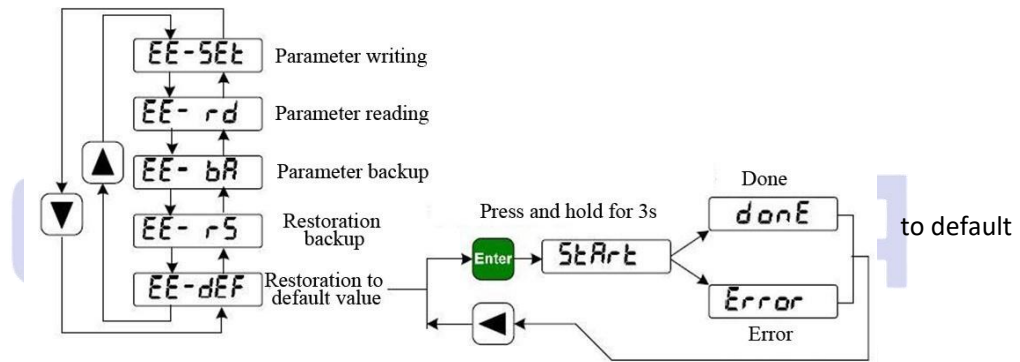

سازمان انواح ماشین ادات صنعتی و ماشین مخصوص
WWW.CNCREZA.IR

Restore to the default parameters under any of the following circumstances:

- ☐ Parameters are disordered, whereby the system fails to work properly;
- ☐ The power fails during saving the parameters, whereby the system automatically restore to the default parameters when power-ON again, but the motor model code (PA1) may not be able to match the drive with motor;
- ☐ The original motor needs to be replaced for the drive, but the new drive does not match the model of the original motor;

To restore the default parameters:

1. Refer to Table A-1 (applicable to MK6 - 2A06 - IUN0) of Appendix I. Make sure the motor model is correctly set in the drive PA1 parameter. Otherwise, the drive may be damaged. Take the MK6-2A06-IUN0 drive for OMA11-06020-3NU motor as an example. The motor model code is 28 according to Table A-1;
2. Change the password parameter PA0 to 385;
3. Change the motor model code parameter PA1 to the selected model code. It is 28 in this example;

4. Write the default parameter value to EEPROM. Select “EE-“ in the first layer and press “Enter” to enter the parameter management mode. Firstly select the operating mode. There are five modes available. Use “↑” and “↓” to select. Select “EE-dEF” and then press “Enter” and hold for more than 3 seconds, it displays “done”, indicating that the parameters are successfully saved. If it fails to save parameters, it displays “Error”.
5. If the previous operation is successful, disconnect the drive input power, and then re-power ON and complete the operation.

8.8.2 Frequent Err-10 alarm

“Err-10” alarm indicates defects in the encoder and its connecting cable. Please check:

- ☐ Whether the connection cable and plug are in good contact;
- ☐ Whether the connection cable is properly welded;
- ☐ Whether the grounding PE terminal of the drive is well grounded;
- ☐ Make sure the encoder cable and the power cable should not share one pipe.

Please contact the seller if the problem is not solved.

APPENDIX (I): motor code (PA1) table

The value of parameter PA1 (model code) must be chosen according to the motor which is to be matched with the drive. Refer to Table A-1. If they do not match, poor performance or alarm may occur. Each model code has a unit combination of default parameters. Parameter PA1 has its default value and corresponding default parameter combination. If you need to modify the model code or to restore to the factory default parameter combination, please refer to 8.8.1.

Motor code PA1	Applicable motor model	Power (kW)	Rated torque (N.m)	Rated speed (r/min)	Remark
23	OMA08-04025-3NU	1.0	4	2500	2500 ppr, 15-line incremental encoder
25	OMA09-04025-3NU	1.0	4	2500	
27	OMA11-05030-3NU	1.5	5	3000	
28	OMA11-06020-3NU	1.2	6	2000	
29	OMA11-04030-3NU	1.2	4	3000	
32	OMA13-04025-3NU	1.0	4	2500	
13	OMA13-05020-3NU	1	5	2000	
30	OMA13-05025-3NU	1.3	5	2500	
12	OMA13-06015-3NU	0.9	6	1500	
31	OMA13-06025-3NU	1.5	6	2500	
33	OMA13-07725-3NU	2.0	7.7	2500	
7	OMA13-10010-3NU	1	10	1000	
11	OMA13-10015-3NU	1.5	10	1500	

Table A-1 Motors applicable to MK6 - 2A06 - IUN0 drive

APPENDIX (II): drive specifications

Model	MK6 - 2A06 - IUN0
Output power (kW)	1.5kw

Input voltage (V)	Single phase or Three phase AC220V (-15 to +10%), 50 to 60Hz	
Encoder type	5V, 2500 pulse incremental encoder, ABZUVW	
Control mode	Position control; pulse speed control	
Regenerative braking	Internal	
Control characteristics	Speed frequency response	Not less than 200Hz
	Speed fluctuation	<± 3% (load change 0 to 100%); <± 2% (input voltage change -15 to +10%) (the value corresponding to the rated speed)
	Speed ratio	1:5000
	Input Pulse frequency	≤500kHz
Position control	Input pulse type	Pulse + sign; CW pulse + CCW pulse; Orthogonal AB phase pulse
	Electronic gear ratio	(1 / 50) to 50
	Feedback pulse	500 to 10,000 pulse / rev (adjustable)
Feedback mode	Motor encoder feedback	
Parameter setting method	Keypad input	
Load inertia used	Less than 3 times of the motor inertia	
Brake mode	Resistance dynamic braking	
Installation mode	Wall mounting (vertical)	
Grounding mode	The housing grounding, grounding resistance ≤0.1Ω	
Monitoring functions	Rotation speed, current position, command pulse accumulated number, position deviation, motor current, command pulse frequency, operating status, input and output status	
Protection functions	Over-speed, main power supply over-voltage or under-voltage, over-current, overload, braking abnormal, encoder abnormal, position-deviation	
Display and operation	6-digit LED seven-segment, 4 keys	
Working environment	Temperature	Operation: 0 to 55°C Storage: -20°C to 80°C
	Humidity	Less than 90% (no condensation)
	Vibration	Less than 0.5G (4.9m/S ²), 10 to 60 Hz (non-continuous operation)

Articles are subjected to change without prior notice.

Ver. 1.1

Latest edition: October 2012

